



WR60A-D4

Worktop 60" Refrigerator with Drawers



WR60A-D4
11/27/18
Item # 13444

W x D x H
60" x 30" x 40"*
*with 6" casters



Item #: _____
Project: _____
Qty: _____
AIA#: _____

Features

- ▶ Engineered to maintain NSF-7 temperatures in 100°F ambient.
- ▶ Stainless steel exterior front, sides, and top with stainless steel interior sides, back, and floor
- ▶ Front breathing air flow design
- Environmentally friendly R290 hydrocarbon refrigerant
- Cabinet and drawers are insulated with 2" CFC free, foamed in place polyurethane
- Drawer slides are constructed of 16 gauge stainless steel with acetal rollers
- Drawer frames are formed of 16 gauge stainless steel and securely fastened in the cabinet
- Top drawers will accommodate (1) 12 x 20 full size pan and (2) ¼ size pans. Bottom drawer will accommodate (1) full size pan
- Extruded aluminum flush mount drawer handle
- Magnetic drawer gasket is easily removable for cleaning
- E-coated evaporator coil
- Standard with 6" casters (two with brakes)
- 10 ft. cord and plug

Dimensions / Capacity

	Two-Section WR60A-D4
Interior Storage Capacity (CF)	17.55 ft ³
Interior Storage Capacity (CF) (AHAM)	15.38 ft ³
Overall Width x Depth (including 1" bumper)	60" x 31"
Height (including 6" casters)	40"
Depth with Drawer Fully Open (including 1" bumper)	52"
Crated Weight	312 lbs.
Crated Length x Width x Height	62.5" x 34" x 40.5"

Electrical / Refrigeration

	Two-Section WR60A-D4
Voltage	115/60/1
HACR Breaker	15.0 Amps
Electrical Connection (NEMA)	5-15P Ⓢ
Voltage Range	104-126
Ambient Temp. Range	45° to 100°F
Control Setpoint Range	32° to 52°F
Amperage	3.3
Energy Consumption (kWh/day) @NSF	2.6
Heat Rejection (BTU/Hr.) @NSF	370
Approx. Nominal Compres. BTU/HR (HP)	1354 (1/5HP)
Refrigerant / Charge Amount (oz)	R290 (2.8 oz)

Options

- 2.25" Casters
- 4" Casters
- Overshelves
- Stainless steel back
- Drawer divider bars

Warranty

- * 3 Year - parts and Labor on entire machine.
 - 5 Year - Parts on Compressor
- Valid in United States, Canada, Puerto Rico and U.S. Territories. Contact factory for warranty in other countries.

Hoshizaki reserves the right to change specifications without notice.



WR60A-D4

Worktop 60" Refrigerator with Drawers



WR60A-D4
11/27/18
Item # 13444

FRONT VIEW

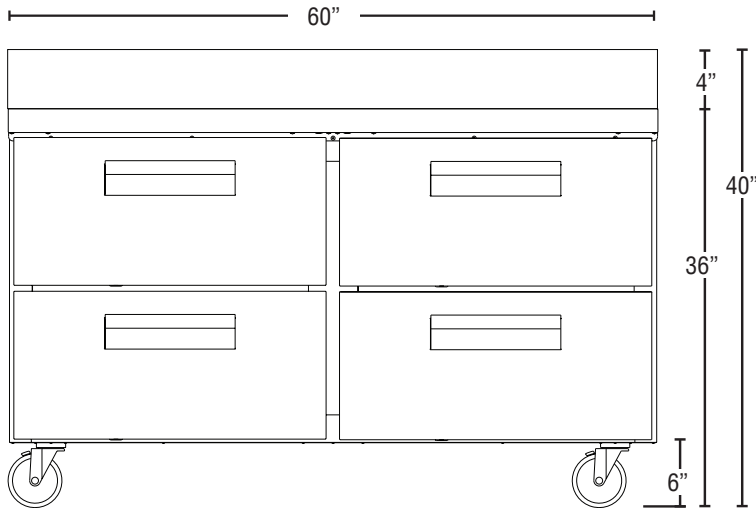

SIDE VIEW

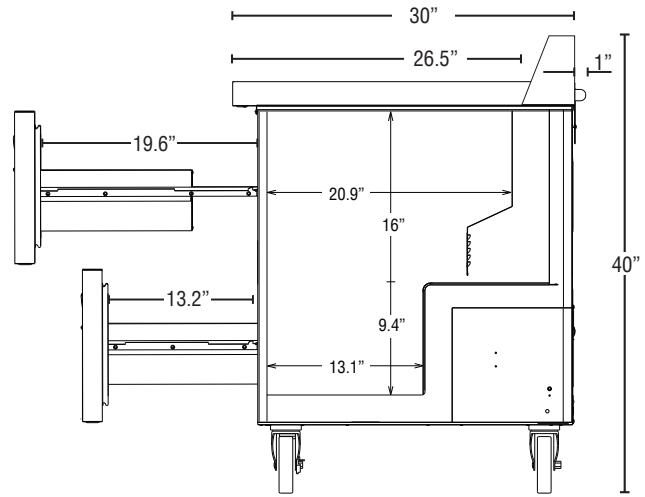

PLAN VIEW

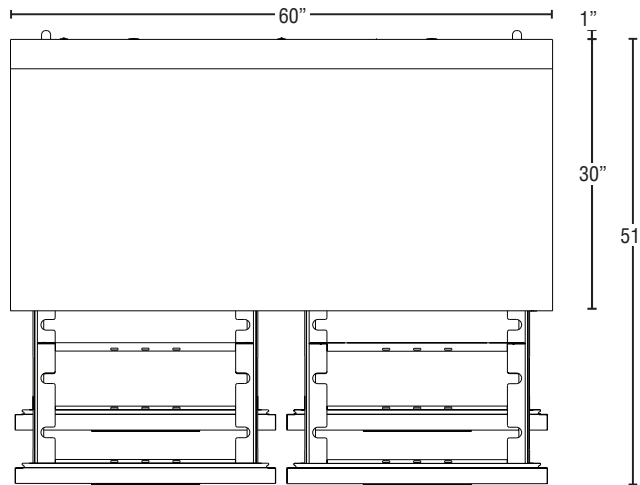

Cabinet Construction

The exterior cabinet top, front, and sides, are constructed of high quality stainless steel. The exterior back and bottom are constructed of coated steel. The cabinet interior features stainless steel back, sides, and floor with a stainless steel top. One heavy duty epoxy coated shelf per section is standard. Mounted on anodized aluminum pilasters the shelves are adjustable in 1/2" increments. Cabinet walls are insulated with 2" CFC free, foamed in place polyurethane. 6" polyolefin, stem casters (two with brakes) are standard.

Drawer Construction

Drawer fronts are constructed of high grade stainless steel inside and out and drawers are insulated with 2" free foamed in place polyurethane. The bottom drawers will accommodate 6" deep pans. Full size pans in the top drawer can be oriented longways from front to back or left to right. The top drawer will accommodate 4" deep pans with either orientation. The top drawer will also accommodate 6" deep full-size pans when oriented longways from left to right and provide capacity for (2) 1/4 size pans 4" deep in the rear of the drawer. HS-5433 divider bar is recommended for this configuration. Drawer frames are formed of 16 gauge stainless steel and securely fastened in the cabinet. The drawer slides are 16 gauge stainless steel with acetal rollers to prevent metal to metal contact between the drawer slides and reduce wear. The drawer slides have a dynamic load capacity of 175 lbs. and have been life tested (fully loaded) three hundred thousand openings and closings without showing significant wear. The flush mount handles are constructed of extruded aluminum. Snap-in magnetic drawer gaskets are durable and easily removed for cleaning.

Refrigeration System

The high efficiency refrigeration system is self-contained with an E-coated evaporator for extended life. Condensate removal is accomplished with an energy efficient non-electric evaporation system. A capillary tube controls the flow of environmentally friendly R290 refrigerant through the evaporator. Refrigeration system utilizes an off-cycle defrost to eliminate any ice on the evaporator coil. 115 volt units are equipped with a ten foot cord and plug (20.0 amps or less).