



## FULL SIZE GAS CONVECTION OVEN

VC5GD

### - NOTICE -

This Manual is prepared for the use of trained Hobart Service Technicians and should not be used by those not properly qualified.

This manual is not intended to be all encompassing. If you have not attended a Hobart Service School for this product, you should read, in its entirety, the repair procedure you wish to perform to determine if you have the necessary tools, instruments and skills required to perform the procedure. Procedures for which you do not have the necessary tools, instruments and skills should be performed by a trained Hobart Service Technician.

The reproduction, transfer, sale or other use of this manual, without the express written consent of Hobart, is prohibited.

This manual has been provided to you by ITW Food Equipment Group LLC ("ITW FEG") without charge and remains the property of ITW FEG, and by accepting this manual you agree that you will return it to ITW FEG promptly upon its request for such return at any time in the future.

# TABLE OF CONTENTS

SERVICE UPDATES .....	3
SERVICE UPDATES .....	3
GENERAL .....	4
INTRODUCTION .....	4
OPERATION .....	4
INSTALLATION .....	4
LUBRICATION .....	4
CLEANING .....	4
SPECIFICATIONS .....	4
TOOLS .....	5
REMOVAL AND REPLACEMENT OF PARTS .....	6
COVERS AND PANELS .....	6
CONTROL PANEL COMPONENTS .....	7
COMPONENT PANEL COMPONENTS .....	8
TEMPERATURE PROBE .....	8
GAS BURNER .....	9
GAS ORIFICE .....	10
GAS SOLENOID VALVE .....	10
IGNITION CONTROL MODULE .....	11
SPARK IGNITER AND FLAME SENSE .....	11
BLOWER .....	12
MOTOR .....	13
DOOR SWITCH .....	15
ROLLER LATCH ASSEMBLY (INDEPENDENT DOORS) .....	16
DOOR REMOVAL .....	16
HIGH LIMIT THERMOSTAT .....	16
INTERIOR LIGHTS .....	17
COOLING FAN .....	17
SERVICE PROCEDURES AND ADJUSTMENTS .....	19
TEMPERATURE CONTROL CALIBRATION .....	19
SOLID STATE TEMPERATURE CONTROL TEST .....	20
TEMPERATURE CONTROL BOARD FAULT INDICATOR .....	20
TEMPERATURE PROBE TEST .....	21
GAS VALVE PRESSURE CHECK .....	21
VERIFICATION OF SPARK AT IGNITOR .....	22
BLOWER ADJUSTMENT .....	23
DOOR STRIKE ADJUSTMENT (INDEPENDENT DOORS) .....	23
ELECTRICAL OPERATION .....	25
COMPONENT FUNCTION .....	25
COMPONENT LOCATION .....	26
SEQUENCE OF OPERATION .....	31
DIAGRAMS .....	34
WIRING DIAGRAM AND SCHEMATIC .....	34
TROUBLESHOOTING .....	47
ERROR CODES .....	47
ALL MODELS .....	48

# SERVICE UPDATES

## SERVICE UPDATES

### January 2022

- Updated BLOWER.
- Updated DOOR SWITCH.
- Updated INTERIOR LIGHTS.
- Updated WIRING DIAGRAM AND SCHEMATIC.

### April 2020

- Added new error code. ERROR CODES

### December 2019

- Added ERROR CODES.

### April 2018

- Updated WIRING DIAGRAM AND SCHEMATIC.

# GENERAL

## INTRODUCTION

Models			
MODEL	FEATURES		
	CAVITY DEPTH	TEMPERATURE CONTROL	DOORS (50/50)
VC5GD	26.5"	Solid State	Independent <sup>1</sup> <sup>2</sup>
<sup>1</sup> Simultaneous doors are optional (with or w/o window). <sup>2</sup> Stainless steel doors with window (standard).			

### OPERATION

Refer to Operator's manual for operation instructions ( ), located on Vulcan Resource Center.

<https://my.vulcanfeg.com/resourcecenter/vulcanwolfberkel/default.aspx>

### INSTALLATION

Detailed installation instructions (F31123) are located on the Vulcan resource center.

<https://my.vulcanfeg.com/resourcecenter/vulcanwolfberkel/default.aspx>

### LUBRICATION

Refer to Lubrications Manual F20067 for current values.

### CLEANING

Refer to Operator's manual for cleaning instructions, located on Vulcan Resource Center.

<https://my.vulcanfeg.com/resourcecenter/vulcanwolfberkel/default.aspx>

## SPECIFICATIONS

Electrical	
Voltage	Amps
120/60/1	8.0

Input BTU Rating	
Fuel	BTU
Natural Gas	50,000 input at 5 in. W.C.
Propane	50,000 input at 10.0 in. W.C.

Gas Line Pressures		
Fuel	Recommended Minimum (in. W.C.)	Recommended Maximum (in. W.C.)
Natural Gas	8.0, 6.0	14.0
Propane	11.0	14.0

## TOOLS

### Standard

- Standard set of Hand Tools.
- VOM with minimum of NFPA-70E CATIII 600V, UL/CSA/TUV listed. Sensitivity of at least 20,000 ohms per volt and the ability to measure DC micro amps. Meter leads must also be rated at CAT III 600V.
- Clamp on type amp meter with minimum of NFPA-70E CAT III 600V,UL/CSA/TUV listed.

### Special

- Temperature Tester (Thermocouple Type).
- Manometer.

# REMOVAL AND REPLACEMENT OF PARTS

## COVERS AND PANELS



### ⚠ WARNING

Disconnect the electrical power to the machine and follow lockout / tagout procedures.

#### Bottom Front Cover

1. Remove four screws, two from each side of bottom cover, then remove cover from oven.

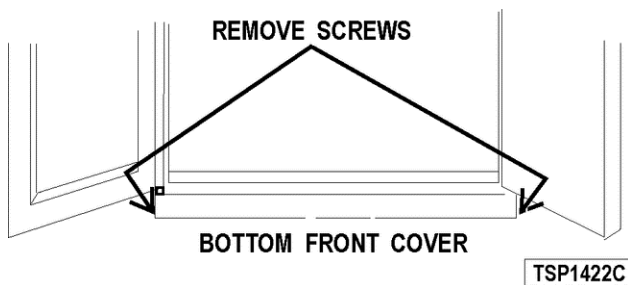

Fig. 1

2. Reverse procedure to install. Verify bottom cover is seated under front plate.

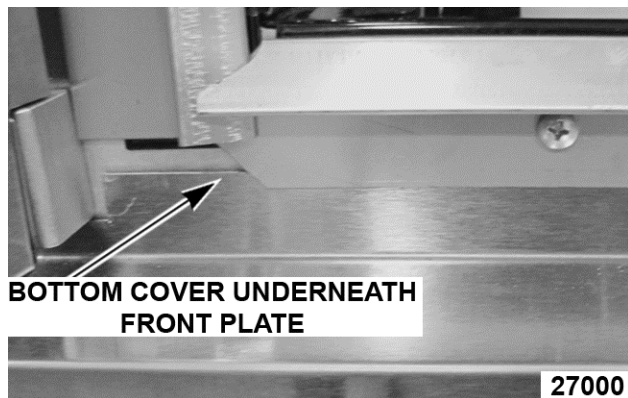

Fig. 2

#### Right Side - Front Panel



### ⚠ WARNING

Disconnect the electrical power to the machine and follow lockout / tagout procedures.

1. Loosen two screws near front of oven, which secure bottom front cover.
2. Loosen screws on left side of front panel and top cover screw.

3. Remove screws along right side and bottom of front panel.

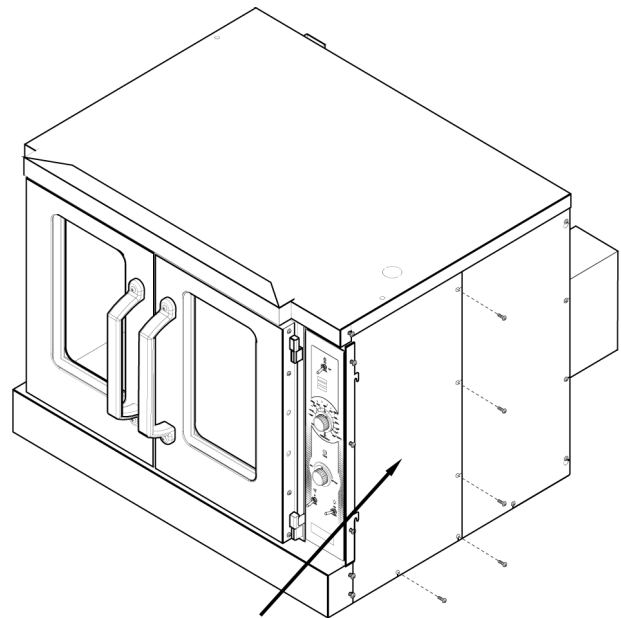

Fig. 3

AI4057

4. Slide right side front panel out.
5. Reverse procedure to install.

#### Right Side - Rear Panel

1. Remove two middle screws along right side of rear panel.
2. Remove screws along left side of rear panel.
3. Remove bottom screws on rear panel.
4. Loosen top and bottom screw along right side of rear panel.

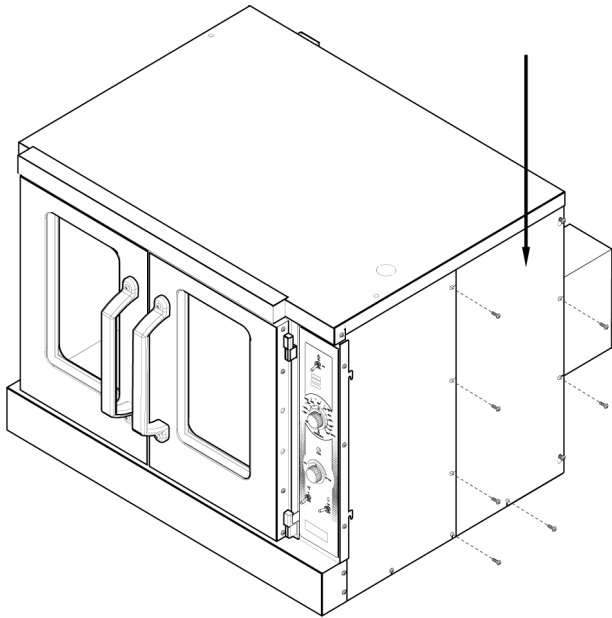

AI4059

**Fig. 4**

- Slide right side rear panel up and to the right to remove.
- Reverse procedure to install.

**Left Side Panel**

- Remove screws along right side, middle left side, and bottom on left side panel.
- Loosen screws on top and bottom on left side of panel.
- Loosen two screws near front of oven, which secure bottom front cover.

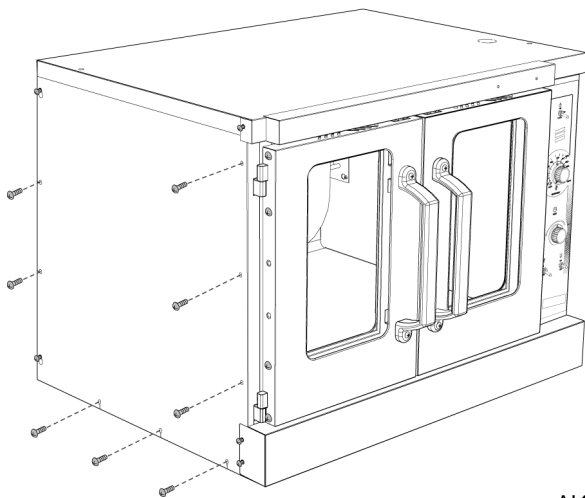

AI4058

**Fig. 5**

- Lift up and pull away to remove.
- Reverse procedure to install.

**Control Panel**

- Remove three screws on the right side which secure the control panel then lift up and pull away.

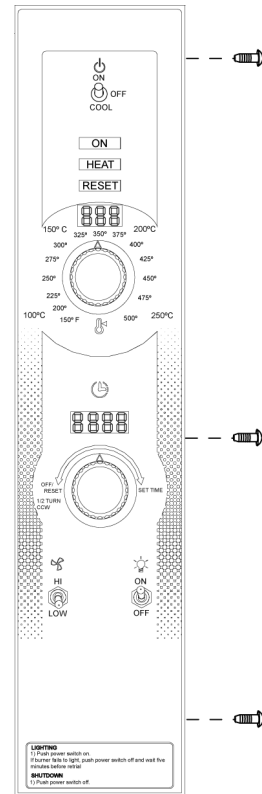

AI4427

**Fig. 6**

- Disconnect the temperature probe leads from the solid-state temperature control.
- Unplug the wire harnesses connector to control panel components.
- Unplug Ground wire from control panel.
- Reverse procedure to install.

**CONTROL PANEL COMPONENTS**



**WARNING**

Disconnect the electrical power to the machine and follow lockout / tagout procedures.

- Remove CONTROL PANEL.
- Remove component being replaced.
- Reverse procedure to install replacement component.
- Check oven for proper operation.

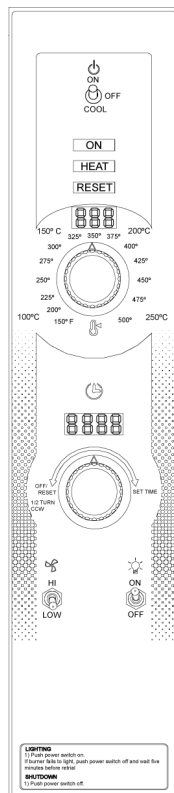

AI4055

Fig. 7

**NOTE:** Panel with standard controls shown.

## COMPONENT PANEL COMPONENTS



### **WARNING**

Disconnect the electrical power to the machine and follow lockout / tagout procedures.

1. Remove RIGHT SIDE PANEL.

**NOTE:** If right side panel is not accessible, this component can be service by removing the CONTROL PANEL.

2. Disconnect the wire leads to component being replaced.
3. Remove the component.
4. Reverse procedure to install component.
5. Check oven for proper operation.

## TEMPERATURE PROBE



### **WARNING**

Disconnect the electrical power to the machine and follow lockout / tagout procedures.

1. Remove RIGHT SIDE PANEL.

**NOTE:** If right side - front panel is not accessible, this component can be serviced by removing CONTROL PANEL.

2. Disconnect the probe leads (1, Fig. 8) from the solid state temperature control.

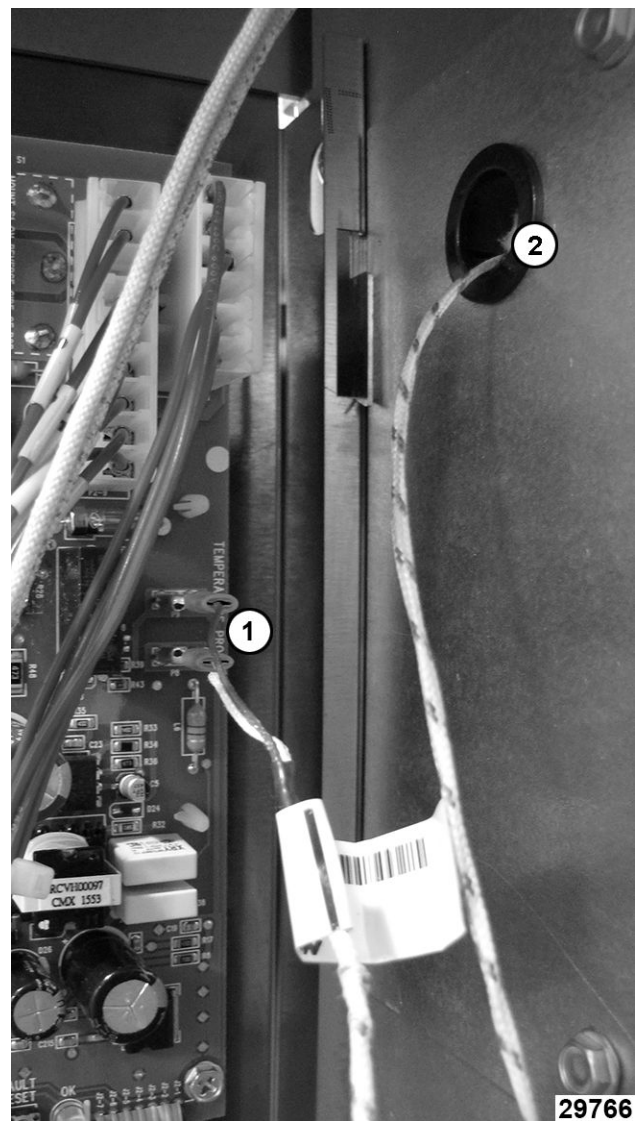

Fig. 8

3. Remove the racks from inside cavity.
4. Remove the probe guard.



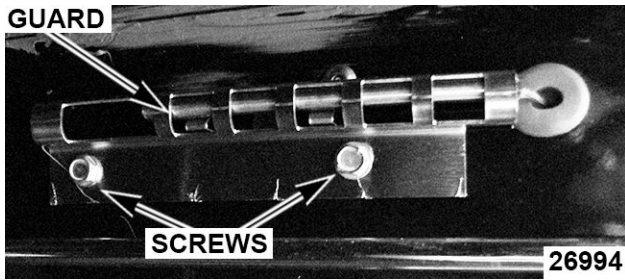

Fig. 9

5. Remove probe by pushing it through the oven wall opening (2, Fig. 8) in control panel area.
6. Reverse the procedure to install the replacement probe.
7. Adjust the temperature control. Refer to: SOLID STATE TEMPERATURE CONTROL TEST.

## GAS BURNER



**⚠ WARNING**

Disconnect the electrical power to the machine and follow lockout / tagout procedures.



**⚠ WARNING**

Shut off the gas before servicing the unit and follow lockout / tagout procedures.

1. Remove BOTTOM FRONT COVER.
2. Disconnect ignition cable and the flame sense lead wire.

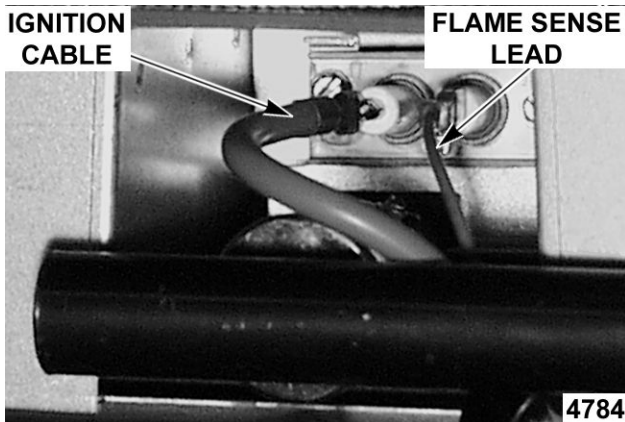

Fig. 10

3. Remove bolts securing gas manifold to oven and place manifold to the side.

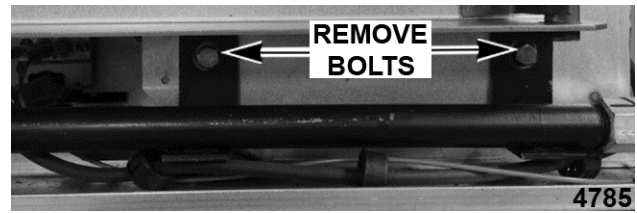

Fig. 11

4. Remove screws securing the burner cover and pull straight out.

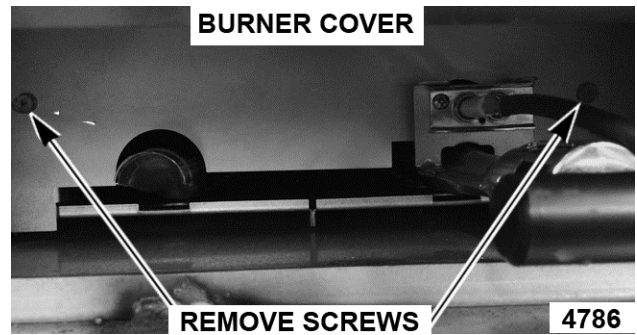

Fig. 12

5. Grasp burner and lift out.

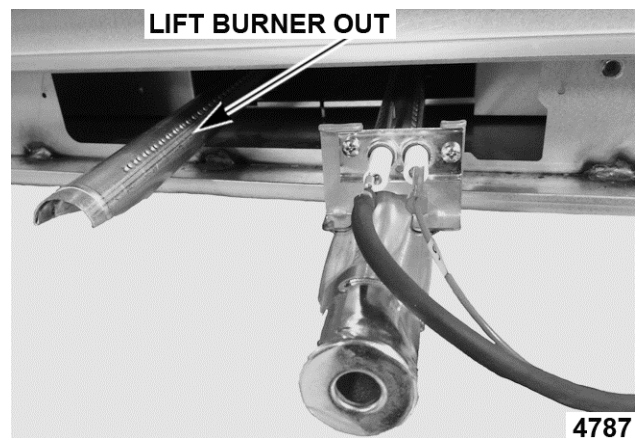

Fig. 13

6. Reverse procedure to install replacement burner.

**NOTE:** Ensure that burner positioning bracket (U-shaped end) is inserted into slot at the rear of burner chamber.

7. Check for proper operation.

## GAS ORIFICE



### ⚠ WARNING

Disconnect the electrical power to the machine and follow lockout / tagout procedures.



### ⚠ WARNING

Shut off the gas before servicing the unit and follow lockout / tagout procedures.

1. Remove BOTTOM FRONT COVER.
2. Remove bolts securing gas manifold to oven and place manifold to the side.

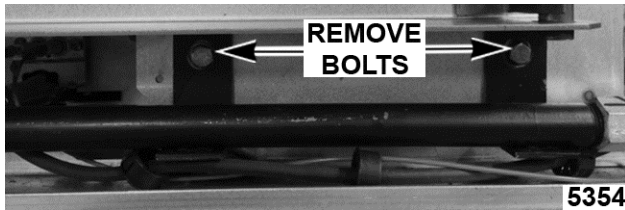

Fig. 14

3. Remove gas orifice from spud on manifold and replace with correct orifice for the given altitude.

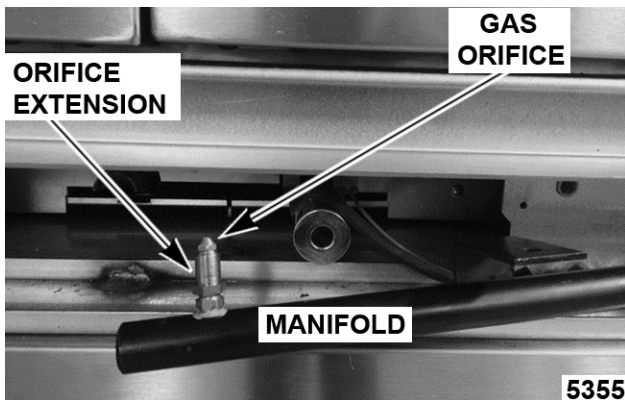

Fig. 15

4. Reverse procedure to install and check for proper operation.

## GAS SOLENOID VALVE



### ⚠ WARNING

Disconnect the electrical power to the machine and follow lockout / tagout procedures.



### ⚠ WARNING

Shut off the gas before servicing the unit and follow lockout / tagout procedures.

1. Remove CONTROL PANEL and RIGHT SIDE FRONT PANEL.

**NOTE:** if right side panel is not accessible, this component can be serviced by just removing CONTROL PANEL.

2. Disconnect lead wires.
3. Disconnect compression fittings to valve.

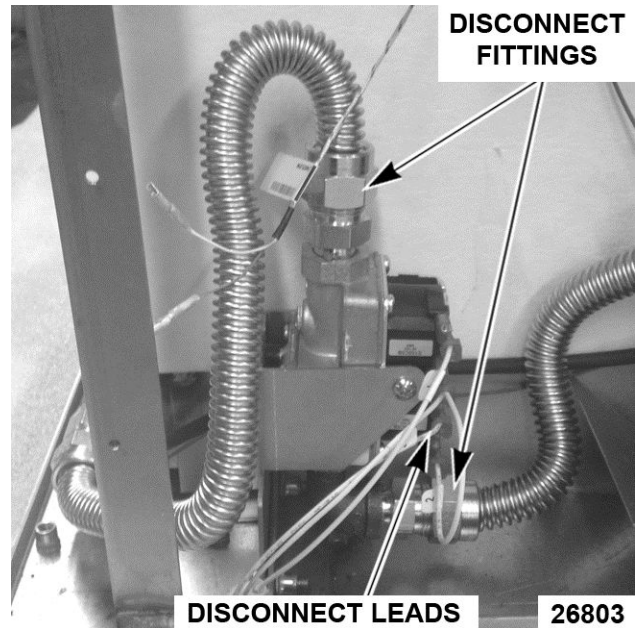

Fig. 16

4. Loosen bolts securing valve and bracket assembly then remove screws securing valve to bracket.

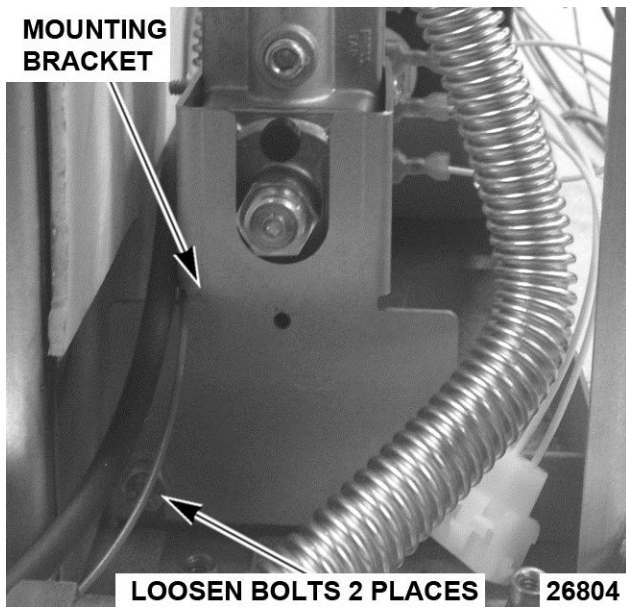

Fig. 17

- Reverse procedure to install replacement gas valve.

**NOTE:** Clean pipe threads and apply pipe joint compound to threads. Any pipe joint compound used, must be resistant to the action of propane gases.

**⚠ WARNING**

All gas joints disturbed during servicing must be checked for leaks. Check with a soap and water solution (bubbles). Do not use an open flame.

- Verify gas pressure as outlined under GAS PRESSURE ADJUSTMENT.
- Check for proper operation.

**IGNITION CONTROL MODULE**



**⚠ WARNING**

Disconnect the electrical power to the machine and follow lockout / tagout procedures.



**⚠ WARNING**

Shut off the gas before servicing the unit and follow lockout / tagout procedures.

- Remove RIGHT SIDE FRONT PANEL.

**NOTE:** If right side panel is not accessible, this component can be serviced by removing CONTROL PANEL.

- Disconnect lead wires (1, Fig. 18) and igniter cable (2, Fig. 18) from ignition module board.

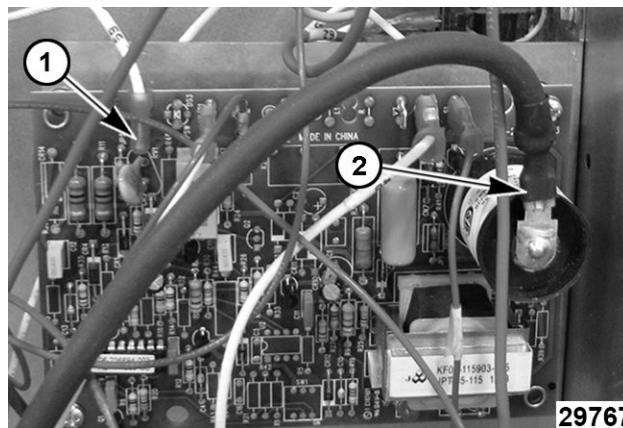

Fig. 18

- Remove the ignition module board from the mounting bracket.
- Reverse the procedure to install replacement ignition module board.

**SPARK IGNITER AND FLAME SENSE**



**⚠ WARNING**

Disconnect the electrical power to the machine and follow lockout / tagout procedures.



**⚠ WARNING**

Shut off the gas before servicing the unit and follow lockout / tagout procedures.

- Remove GAS BURNER.
- Remove screws securing ignitor and flame sense to burner, then remove assembly.



Fig. 19

- Reverse procedure to install assembly and check for proper operation.

**NOTE:** Check to ensure spark gap distance is approximately 1/8". If gap appears to be excessive or poor sparking is occurring, then adjust.

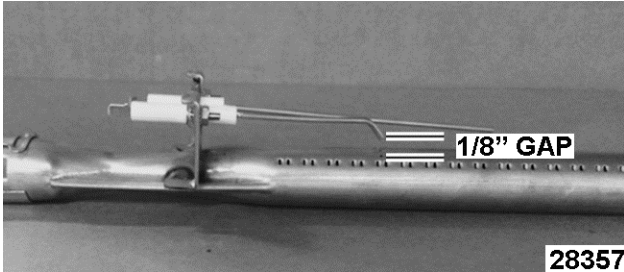

Fig. 20

## BLOWER



### ⚠ WARNING

Disconnect the electrical power to the machine and follow lockout / tagout procedures.



### ⚠ WARNING

Shut off the gas before servicing the unit and follow lockout / tagout procedures.

### Removal

- Remove racks.
- Lay cardboard on bottom of oven cavity to protect surface.
- Remove snorkel (1, Fig. 21) and baffle panel (2, Fig. 21) mounting screws.

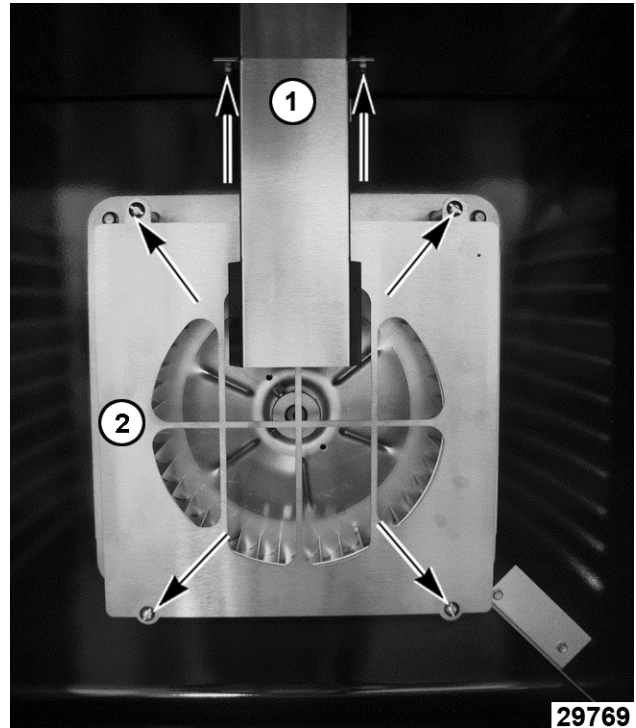

Fig. 21

- Loosen set screws on blower hub.

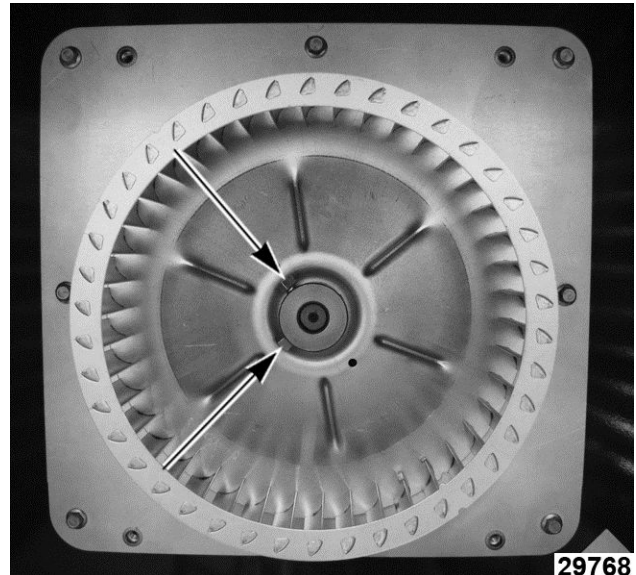

Fig. 22

- Remove blower from motor shaft using a bearing puller.

### Installation

- 1st GENERATION SHOWN IN Fig. 23 SN break ends at 482010857 (Skip to Step 2 for current production)**

Slide blower onto motor shaft until hub is protruding 1/8" (Fig. 23).

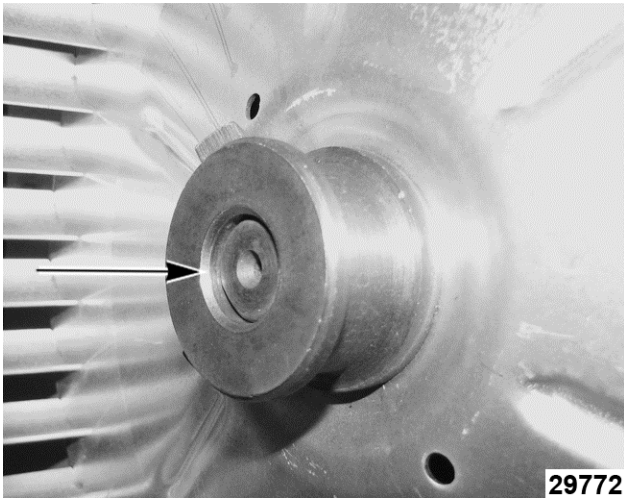

Fig. 23

2. **CURRENT PRODUCTION SN break starts at 482010858**

Slide blower onto motor shaft until hub is flush.

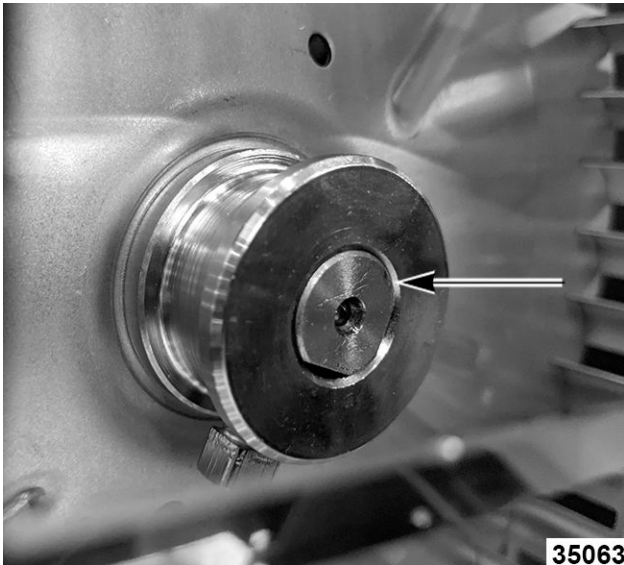

Fig. 24

3. Tighten set screws ( Fig. 22) on blower hub.
4. Install snorkel (1, Fig. 21) and baffle panel (2, Fig. 21).
5. Install racks.
6. Check oven for proper operation.

## MOTOR



### ⚠ WARNING

Disconnect the electrical power to the machine and follow lockout / tagout procedures.



### ⚠ WARNING

Shut off the gas before servicing the unit and follow lockout / tagout procedures.

**NOTE:** 1ST Generation motor is the Marathon motor. Fir Motor is current production.

1. Remove BLOWER.
2. Remove bolts (1, Fig. 25) that secure the motor mounting plate to rear wall.

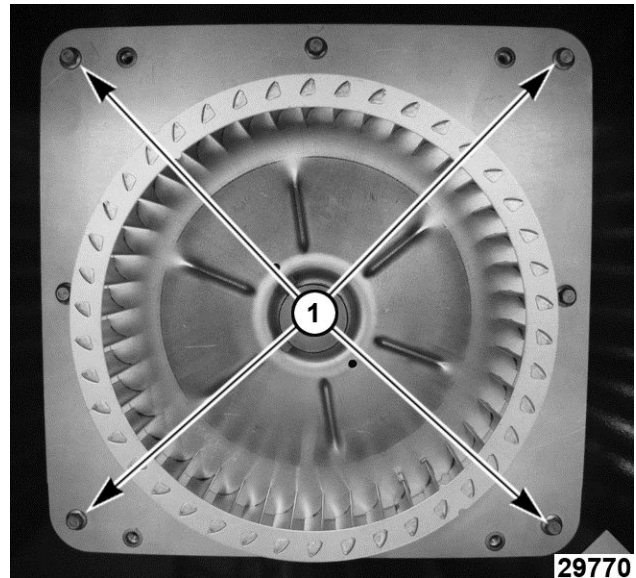

Fig. 25

3. Pull motor assembly into oven cavity and place it on cardboard.
4. Remove junction box cover on motor, disconnect lead wires and remove conduit.
5. Remove motor mounting bolts and flat washers then lift the motor from mounting plate.
6. Position replacement motor on motor mounting plate and install mounting bolts and washers. Hand tighten mounting bolts only.
7. Reconnect lead wires at motor, replace conduit and junction box cover.

**NOTE:** Check data plate on motor for wiring schematic. Motor must rotate *clockwise* when viewed from shaft end.

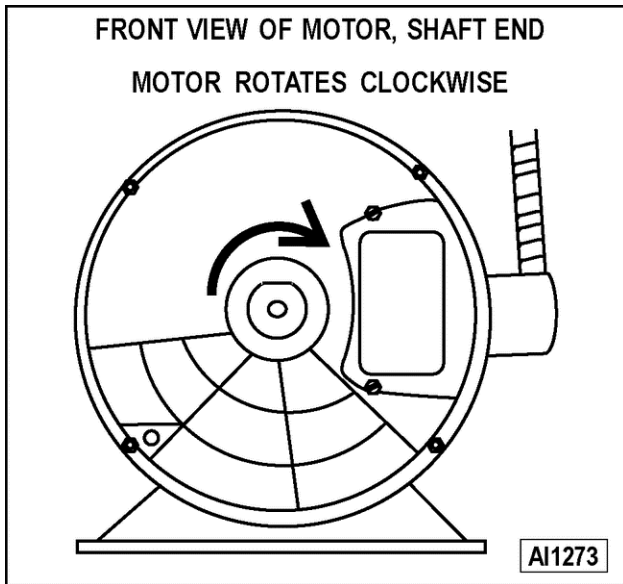

Fig. 26

8. **1ST GENERATION SHOWN IN (Skip to Step 9 for current production.)**

Slide blower onto motor shaft until hub is protruding 1/8" (Fig. 27).

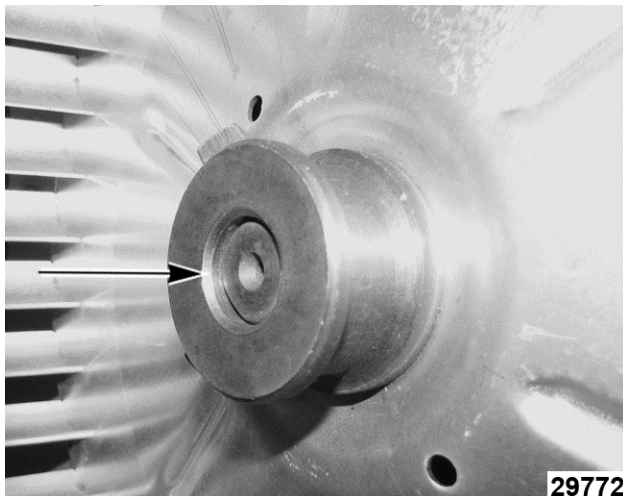

Fig. 27

9. **CURRENT PRODUCTION**

Slide blower onto motor shaft until hub is flush.

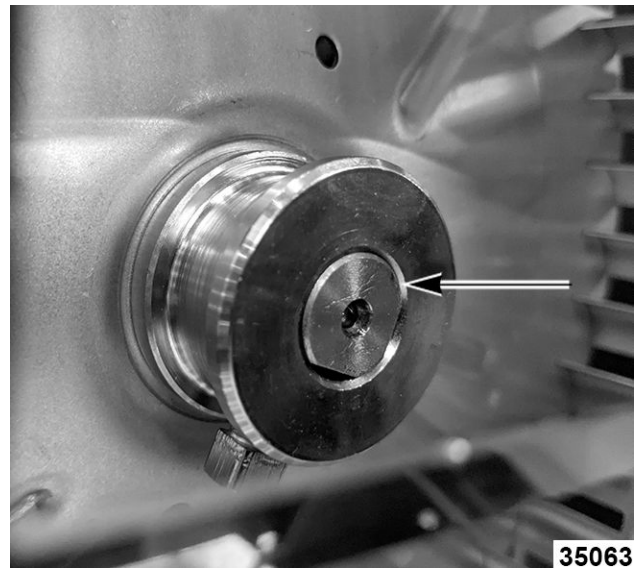
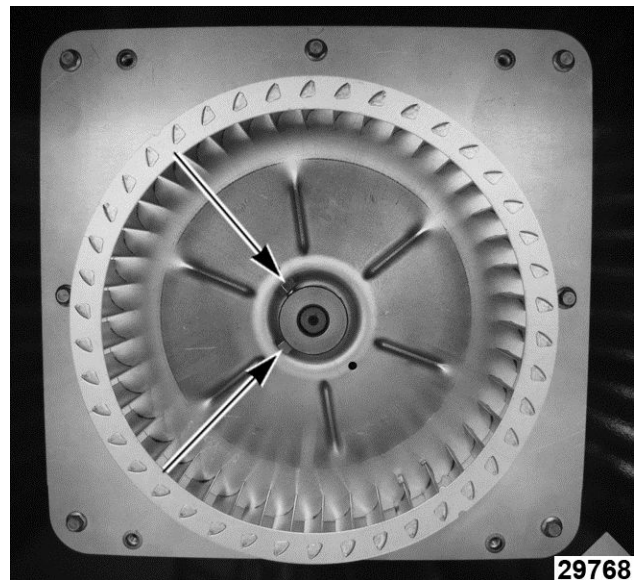

Fig. 28

10. Tighten set screws.



11. Adjust motor position until blower is parallel to motor mounting plate as outlined under **BLOWER ADJUSTMENT**.
12. Install motor mounting plate.
13. Install snorkel (1, Fig. 30) and baffle panel (2, Fig. 30).

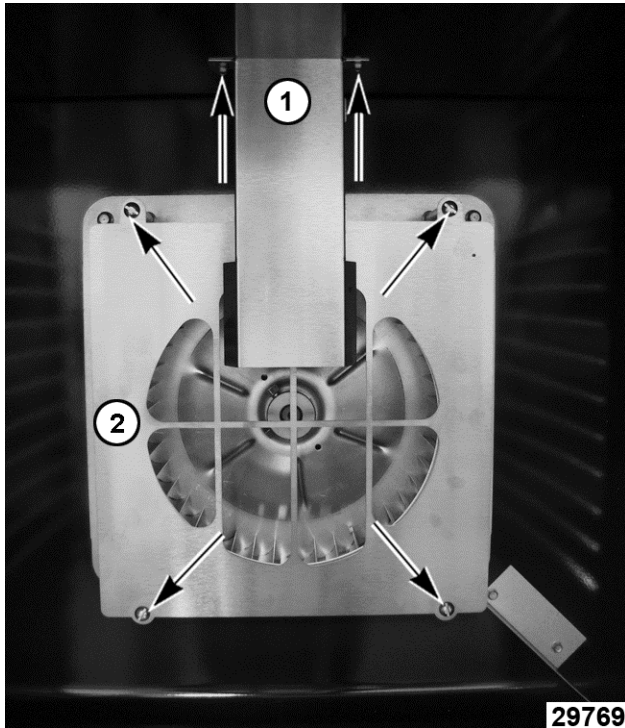

Fig. 30

14. Remove cardboard from the bottom of the oven cavity.
15. Install racks.
16. Check oven for proper operation.

## DOOR SWITCH



### ⚠ WARNING

Disconnect the electrical power to the machine and follow lockout / tagout procedures.

1. Remove BOTTOM FRONT COVER.
2. Remove door switch mounting hardware.

1st GENERATION SHOWN IN Fig. 31

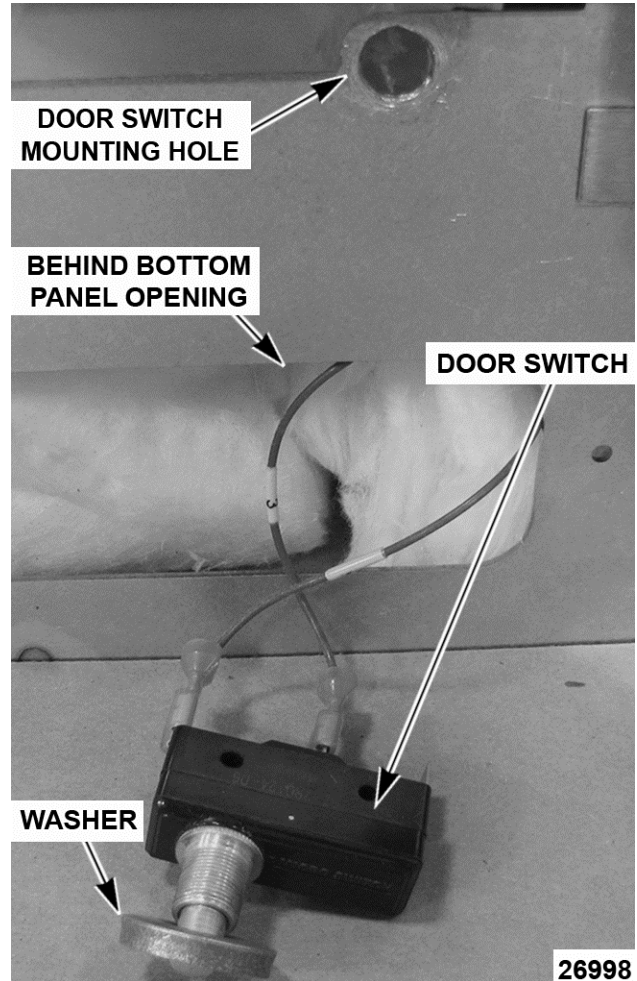

Fig. 31

CURRENT PRODUCTION SHOWN IN Fig. 32

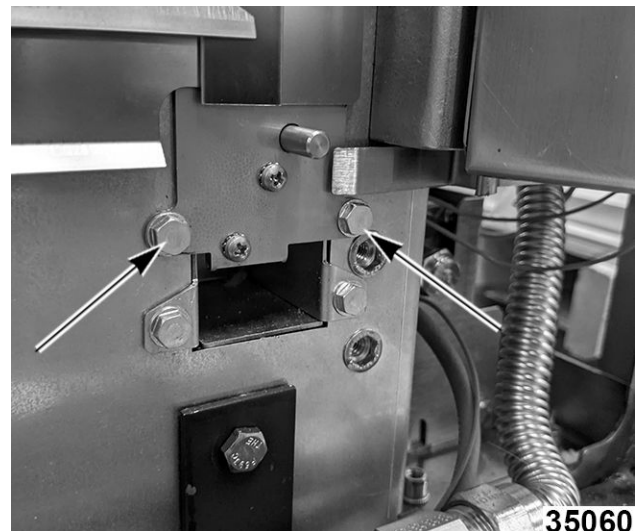

Fig. 32

3. Pull door switch and washer out through bottom panel opening.



Fig. 33

4. Disconnect lead wires to door switch.
5. Reverse procedure to install replacement switch.

### ROLLER LATCH ASSEMBLY (INDEPENDENT DOORS)



#### **WARNING**

Disconnect the electrical power to the machine and follow lockout / tagout procedures.

1. Remove screws that attach roller latch assembly to door.

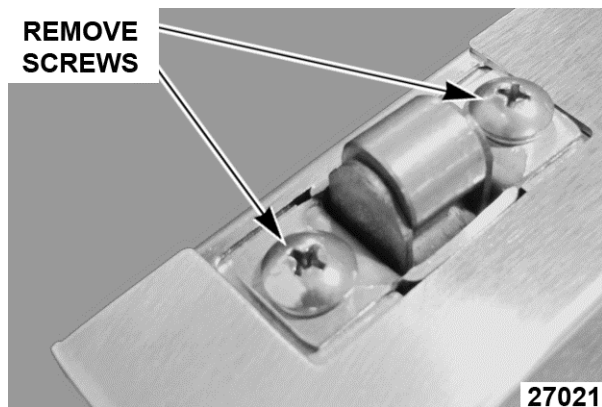

Fig. 34

2. Reverse procedure to install.

### DOOR REMOVAL

1. Open door to a 90° angle.
2. Lift door up off hinges to remove.



Fig. 35

3. Reverse procedure to install the replacement door.
4. Check oven for proper operation.

### HIGH LIMIT THERMOSTAT



#### **WARNING**

Disconnect the electrical power to the machine and follow lockout / tagout procedures.

1. Remove racks.
2. Remove high limit thermostat cover/mounting plate from inside oven cavity at the top.



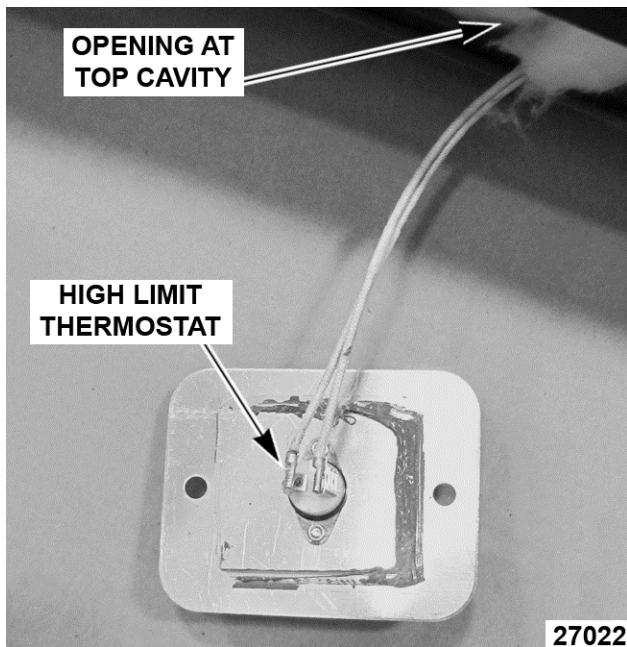

Fig. 36

3. Disconnect lead wires from high limit thermostat.

**NOTE:** Remove old RTV sealer from cover and mating surfaces inside oven cavity and apply new high temperature RTV sealer before installing.

4. Reverse procedure to install.

## INTERIOR LIGHTS



### ⚠ WARNING

Disconnect the electrical power to the machine and follow lockout / tagout procedures.

### NOTICE

Do not touch the Halogen lamp with bare hands. If lamp is exposed to oil from the skin, the life will be reduced. Ensure lamp is free from oil and dirt before replacing.

#### Bulb Replacement

1. Pull lamp cover off.
2. Grasp lamp using a clean cloth and remove from lamp assembly.

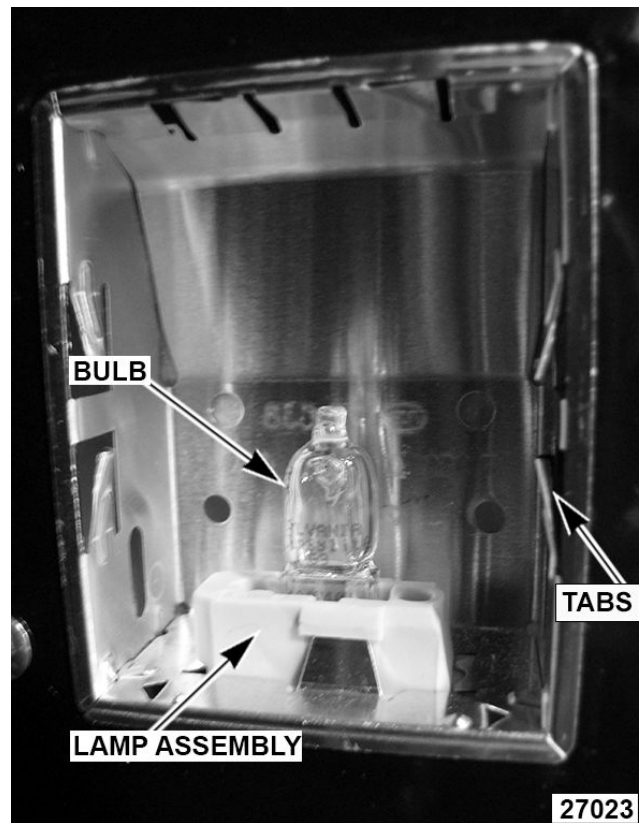

Fig. 37

3. Reverse procedure to install new bulb.

#### Lamp Assembly Replacement

1. Remove racks.
2. Pull lamp cover off.
3. Pull lamp assembly out.
4. Reverse procedure to install new lamp assembly.

## COOLING FAN



### ⚠ WARNING

Disconnect the electrical power to the machine and follow lockout / tagout procedures.

1. Remove RIGHT SIDE FRONT PANEL.

**NOTE:** If right side - front panel is not accessible, this component can be serviced by removing CONTROL PANEL.

2. Remove wire nuts from fan wire connections.

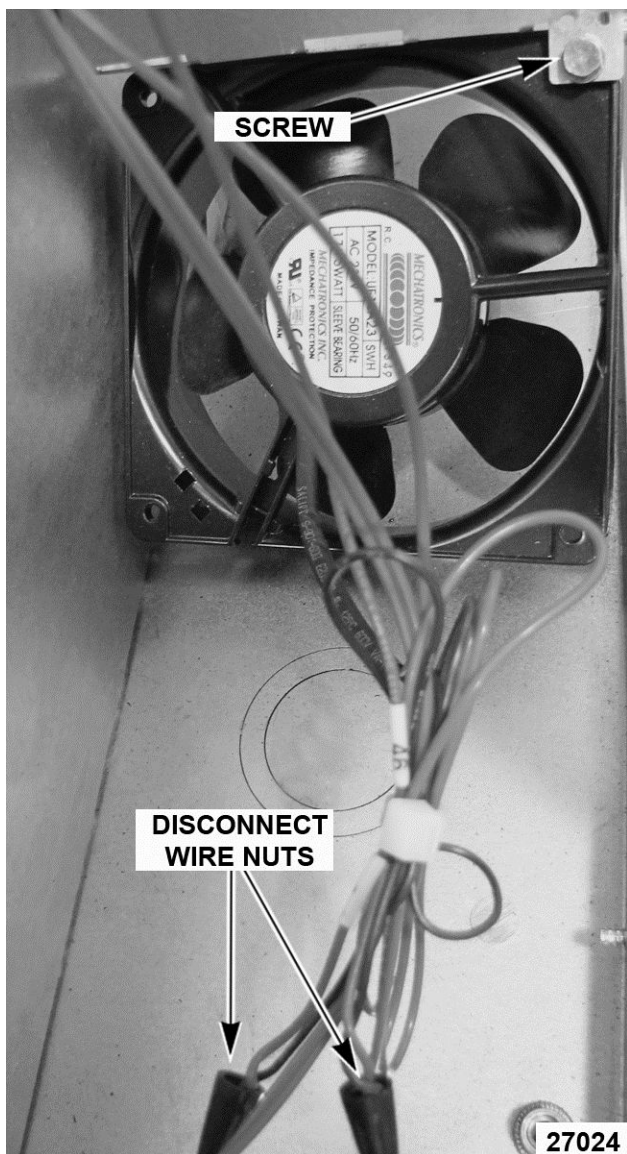

Fig. 38

3. Loosen tab screw holding fan to component panel.
4. Rotate tab so that fan will clear and remove fan.
5. Reverse procedure to install fan and check for proper operation.

**NOTE:** Fan must be installed so air is pulled from outside the rear of oven and blown into control area. The arrow on the fan body indicates "air flow" direction and should be pointing toward controls.

# SERVICE PROCEDURES AND ADJUSTMENTS

## TEMPERATURE CONTROL CALIBRATION



### ⚠ WARNING

Certain procedures in this section require electrical test or measurements while power is applied to the machine. Exercise extreme caution at all times and follow Arc Flash procedures. If test points are not easily accessible, disconnect power and follow Lockout/Tagout procedures, attach test equipment and reapply power to test.

**NOTE:** The temperature control module has a programmable offset that can be applied to the set temperature. This can be adjusted in 5 degree increments up to 20 degrees in either direction.

1. Place a thermocouple in center of oven cavity.
2. Remove RIGHT SIDE FRONT PANEL to view back of temperature control board.
3. Turn oven on and set to 350° Fahrenheit.
4. Watch the red fault indicator. If light comes on see TEMPERATURE CONTROL BOARD FAULT INDICATOR for troubleshooting tips. If light stays off go to next step.
5. Allow oven to stabilize (typically 3 cycles)
6. Record temperature when heat light goes off and comes on for at least 2 cycles.
7. Calculate differential by subtracting temperature when lamp goes out from temperature when lamp comes on.

**Differential = (Heat Lamp OFF - Heat Lamp ON)**

- If differential is less than 20 degrees, temperature control circuit is functioning properly. If it is more turn off oven and replace TEMPERATURE PROBE.
- Repeat CALIBRATION steps. Calculate average temperature (Heat Lamp OFF temperature + Heat Lamp ON temperature divided by 2).

**Average = (Heat Lamp OFF + Heat lamp on divided by 2)**

- If Average is less than 10° Fahrenheit from dial setting, thermostat is properly calibrated.

- If it is more than 10° Fahrenheit, then complete following steps.
  1. Remove temperature control knob.



Fig. 39

2. Press and hold both + (plus) and the - (minus) buttons for 3 seconds.

**NOTE:** Power light will start blinking and display will show current offset.

3. Push "+" or "-" button to increase or decrease offset.

**NOTE:** Each press will change offset by 5 degrees.

**NOTE:** After 5 seconds of no activity controller will automatically exit calibration mode.

## SOLID STATE TEMPERATURE CONTROL TEST



### ⚠ WARNING

Certain procedures in this section require electrical test or measurements while power is applied to the machine. Exercise extreme caution at all times and follow Arc Flash procedures. If test points are not easily accessible, disconnect power and follow Lockout/Tagout procedures, attach test equipment and reapply power to test.

1. Remove RIGHT SIDE FRONT PANEL.

**NOTE:** If right side panel is not accessible, this component can be serviced by removing CONTROL PANEL.

2. Place a thermocouple in the geometric center of oven cavity.

**NOTE:** Oven temperature must be below 450°F.

3. Set the temperature control to the maximum setting.
4. The green indicator light will flash once every 3 seconds if the board is receiving power. If it is off the problem is not with the Temperature Control Board. Refer to "TROUBLESHOOTING".
5. If the red fault indicator comes on count the number of times it flashes and check TEMPERATURE CONTROL BOARD FAULT INDICATOR table to identify fault code.

## TEMPERATURE CONTROL BOARD FAULT INDICATOR



### ⚠ WARNING

Certain procedures in this section require electrical test or measurements while power is applied to the machine. Exercise extreme caution at all times and follow Arc Flash procedures. If test points are not easily accessible, disconnect power and follow Lockout/Tagout procedures, attach test equipment and reapply power to test.

Code	Description	Action
1	Open Probe	Verify probe is plugged in. Replace <u>TEMPERATURE PROBE</u> .
2	Shorted Probe	Replace <u>TEMPERATURE PROBE</u> .
3	No Heat	Run <u>TEMPERATURE PROBE TEST</u> .
4	PCB Overheat	Verify cooling fan works. Clean air intake at back of oven.
5	No Output	Replace temperature control PCB. Refer to: <u>CONTROL PANEL COMPONENTS</u>

Code	Description	Action
6	Output Shorted	Replace temperature control PCB. Refer to: <u>CONTROL PANEL COMPONENTS</u>
7	Call for Heat Timeout	See TROUBLESHOOTING - NO IGNITION

## TEMPERATURE PROBE TEST



### **WARNING**

Certain procedures in this section require electrical test or measurements while power is applied to the machine. Exercise extreme caution at all times and follow Arc Flash procedures. If test points are not easily accessible, disconnect power and follow Lockout/Tagout procedures, attach test equipment and reapply power to test.

- Place a shielded thermocouple in center of oven cavity.
- Turn oven on and set to 350° Fahrenheit.
- Remove temperature control knob.
- Hold down "-" (minus) button for 3 seconds to enter diagnostic mode.

**NOTE:** Display should now show oven temperature reported by probe.

- Allow temperature to stabilize (typically 3 cycles).
  - If thermocouple temperature is within 5° Fahrenheit of display temperature, probe is functioning properly.
  - If temperature difference between thermocouple and display is greater than 5 degrees but less than 20° Fahrenheit, refer to: TEMPERATURE CONTROL CALIBRATION to calibrate.
  - If temperature difference is greater than 20° Fahrenheit turn off oven, replace TEMPERATURE PROBE, then repeat TEMPERATURE PROBE TEST.

TEMP (°F)	OHMS*	TEMP (°F)	OHMS*
77	90,000	360	822
240	4,077	380	656
260	3,016	400	529

TEMP (°F)	OHMS*	TEMP (°F)	OHMS*
280	2,266	425	424
300	1,726	450	334
320	1,332	475	266
340	1,041		

(\*) Resistance in ohms ± 10%

## GAS VALVE PRESSURE CHECK



### **WARNING**

Disconnect the electrical power to the machine and follow lockout / tagout procedures.

- Turn gas supply off at manual shutoff valve.
- Remove RIGHT SIDE FRONT PANEL.

**NOTE:** If right side panel is not accessible, this component can be serviced by removing CONTROL PANEL.

- Remove plug from manifold pressure port (1, Fig. 40).

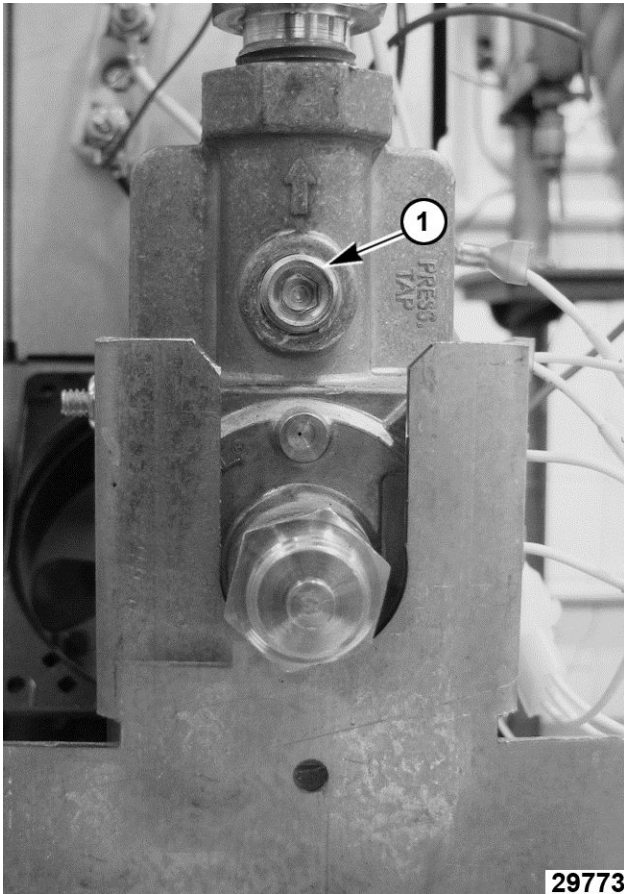

Fig. 40

4. Install hose barb adapter and attach manometer tube.
5. Turn gas supply to oven back ON.
6. Plug unit in and turn power switch ON.
7. Set temperature control to highest setting and allow burner to ignite.

**NOTE:** The burner must be lit during test.

**NOTE:** Accurate gas pressure readings can only be made with gas on and burner lit.

GAS TYPE	PRESSURE READING (IN W.C.)			
	MANIFOLD	LINE		
		RECOMMEND	MIN	MAX
Natural	5.0	8.0	6	14
Propane	10	11.0	11	14

**NOTE:** If incoming line pressure to valve is **less** than minimum stated, manifold pressure will not be maintained.

**NATURAL GAS**

- If incoming pressure to valve is between 6" W.C. and 14" for Natural gas and manifold pressure is not maintaining 5" W.C., and the cap is correctly positioned, replace valve.

**PROPANE**

- 11" W.C. and 14" for Propane gas and manifold pressure is not maintaining 10" W.C., and the cap is correctly positioned, replace the valve.

**VERIFICATION OF SPARK AT IGNITOR**



**WARNING**

Disconnect the electrical power to the machine and follow lockout / tagout procedures.



**WARNING**

Shut off the gas before servicing the unit and follow lockout / tagout procedures.

1. Remove BOTTOM FRONT COVER.
2. Disconnect high voltage "ignition cable" from spark ignitor.

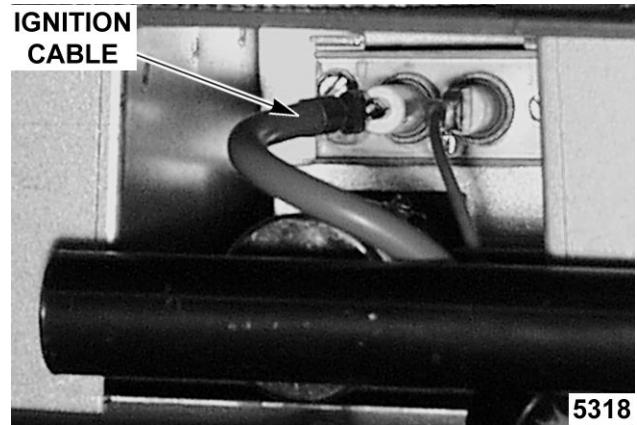

Fig. 41

**WARNING**

**DO NOT HOLD THE WIRE WITH YOUR HANDS FOR THIS TEST. THE MANUAL GAS VALVE MUST BE CLOSED.**

3. Clamp ignition cable in a manner that will position the end of cable 3/16" from oven frame (bare metal surface).

**⚠ WARNING**

It is critical that the cable be held 3/16" away from surface of oven frame or sparking may not occur even though sparking circuit is functioning properly.

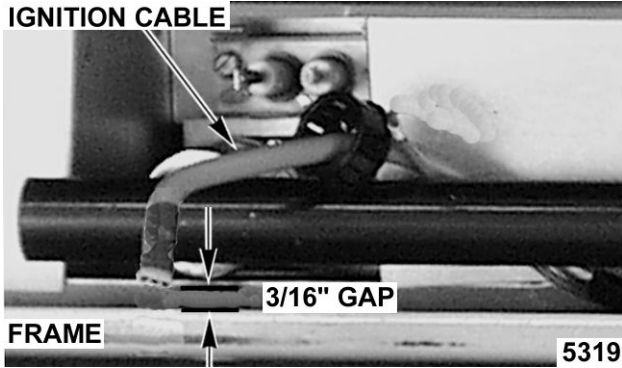

Fig. 42

4. Plug oven in and set temperature control to maximum setting.
5. Turn power switch ON.
6. Sparking should occur after a 4 second delay, for a duration of 7 seconds, then repeat twice after a 15 second purge time. Arching from ignition cable to oven frame should be observed.

**BLOWER ADJUSTMENT**



**⚠ WARNING**

Disconnect the electrical power to the machine and follow lockout / tagout procedures.



**⚠ WARNING**

Shut off the gas before servicing the unit and follow lockout / tagout procedures.

1. Remove **BLOWER**.
2. Loosen motor mounting bolts.
3. Adjust the motor position until blower is parallel to and 1/4 inch away from motor mounting plate. Check for squareness of the blower to motor mounting plate at top, bottom, left and right of blower.
  - If blower is square, tighten motor mounting bolts and proceed to Step 4.

- If blower is not square, continue adjusting until proper spacing is achieved, then tighten motor mounting bolts.

**NOTE:** If necessary, place shims between motor and frame.

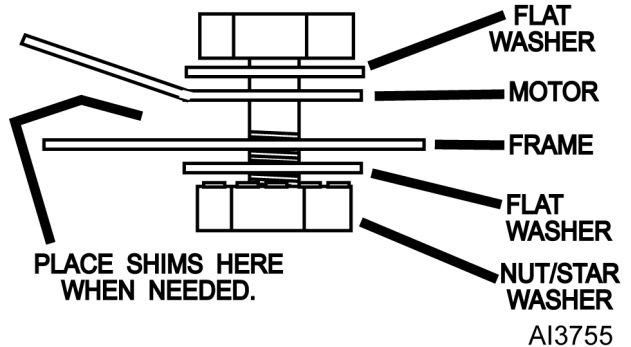

Fig. 43

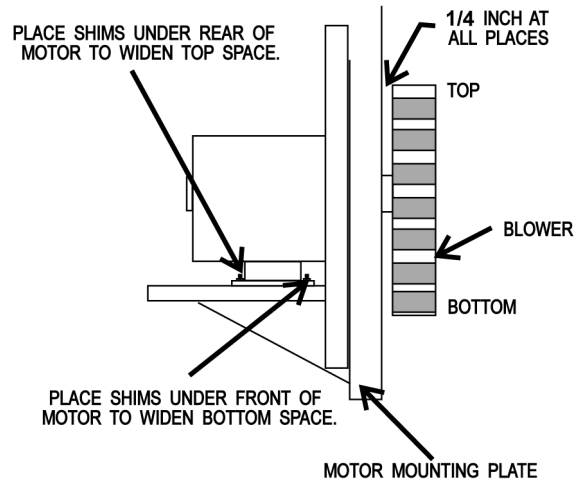
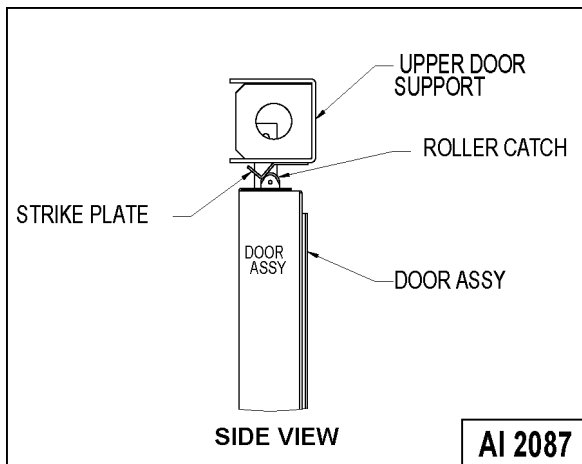

Fig. 44

4. Reverse procedure to install.

**DOOR STRIKE ADJUSTMENT (INDEPENDENT DOORS)**

1. Open doors and inspect door strike for proper shape.
  - A. Bend strike plate.



**Fig. 45**

2. Open and close doors several times while observing roller latch and strike plate operation.
  - A. Replace ROLLER LATCH ASSEMBLY (INDEPENDENT DOORS) if malfunctioning.
3. Each oven door should open with a force of 8 to 25 pounds when pulled at the handle. The adjustments must allow the doors to remain closed during normal operation and allow opening without exertion by the user.



# ELECTRICAL OPERATION

## COMPONENT FUNCTION

<b>Power Switch (S1) . . . .</b>	Determines the mode of operation; ON, OFF, or COOL DOWN.
<b>Oven Light Switch (S3) .....</b>	Controls the oven cavity lights.
<b>Fan Speed Switch Hi/Low (S2) .....</b>	Controls blower motor speed between Hi and Low settings.
<b>Buzzer .....</b>	Signals the end of a "Cook" cycle when cooking time expires.
<b>Door Switch .....</b>	Allows the oven to operate when the doors are closed but stops the oven from operating when the doors are opened.
<b>Blower Motor .....</b>	Operates the oven cavity blower (convection fan). Also, an internal centrifugal switch on the motor is utilized to allow the connection of power to the heat relay (R3) when the motor is at operating speed.
<b>Transformer (T1) . . . .</b>	Provides 24VAC power to the ignition control module and heating circuit.
<b>Solid State Temperature Control (VC5GD) .....</b>	Monitors temperature sensor and regulates the oven cavity temperature by controlling the heat relay (R3) through the blower motor centrifugal switch contacts.
<b>High Limit Thermostat .....</b>	Protects the oven from temperatures above 550°F by removing power from the 1st valve (safety) on the dual solenoid gas valve which stops the flow of gas to the burner. Auto resets at 500°F.
<b>Ignition Control Module .....</b>	Controls the gas ignition cycle - Energizes the 2nd valve (main) on the dual solenoid gas valve, generates spark for burner ignition, monitors the presence of a flame and controls the No Ignition light. The ignition times are: 4 second self-diagnostic test (initial power ON); 7 second ignition trial; 3 ignition trials with a 15 second purge between each trial.
<b>Igniter/Flame Sense .....</b>	Ignites the gas and senses the presence of a flame. The flame presence generates a micro-amp "flame sense" current that is monitored by the ignition control module. A flame sense current of 0.7 micro amp (minimum) is required to maintain burner ignition.
<b>Power On Light .....</b>	Lit whenever the power switch (S1) is turned to ON or Cool Down mode.
<b>Heat Light .....</b>	Lit whenever temperature control is calling for heat.
<b>Reset Light .....</b>	Lit when power is turned ON, during ignition trial & gas purge time and when no flame is detected by flame sensor. If the oven fails to ignite after 3 attempts, it will remain lit until power is reset.
<b>Temperature Probe ...</b>	Senses the oven temperature for the solid state temperature control or computer control. On oven models using the solid state control, converts the temperature into a resistance valve which is monitored by the temperature control board. As temperature increases the resistance value decreases.
<b>Gas Valve (Dual Solenoid) .....</b>	Allows gas flow to the burner when the 1st valve (safety) and 2nd valve (main) solenoid coils are both energized.
<b>Cooling Fan .....</b>	Circulates cooler air from rear of oven forward to cool components in the control area.
<b>Timer .....</b>	5 HR Cook timer.

**COMPONENT LOCATION**

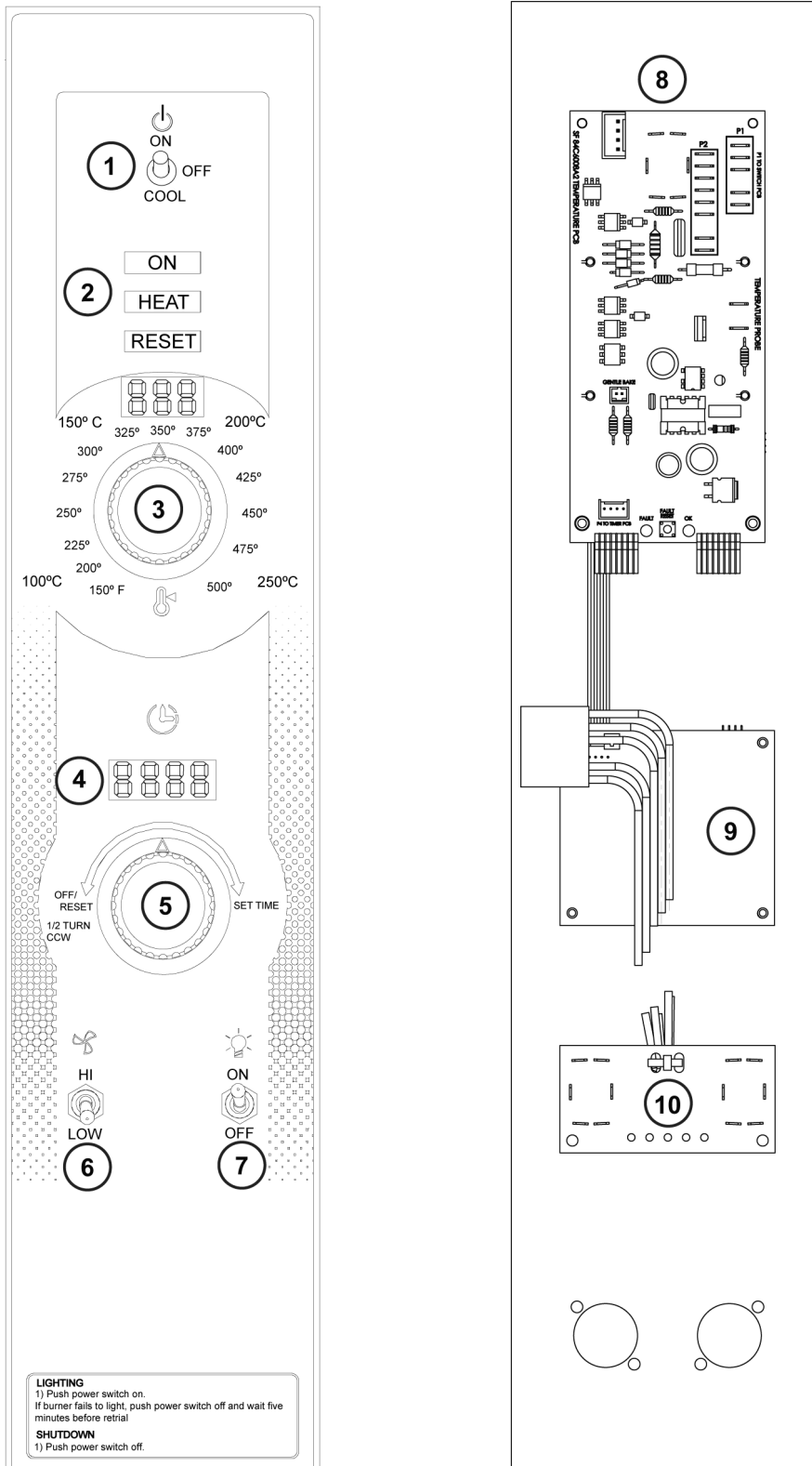

A14062

Fig. 46

<b>CONTROL PANEL</b>	
1	ON/ OFF / COOL Switch
2	ON / HEAT / RESET Lights
3	Temperature Dial
4	Digital Time Readout
5	Timer
6	HI / LOW Fan Setting
7	Light ON / OFF Switch
8	Temperature Control Board
9	Timer Board
10	Light and Fan Speed Switch Board

**CONTROL PANEL DIGITAL TEMPERATURE READOUT**

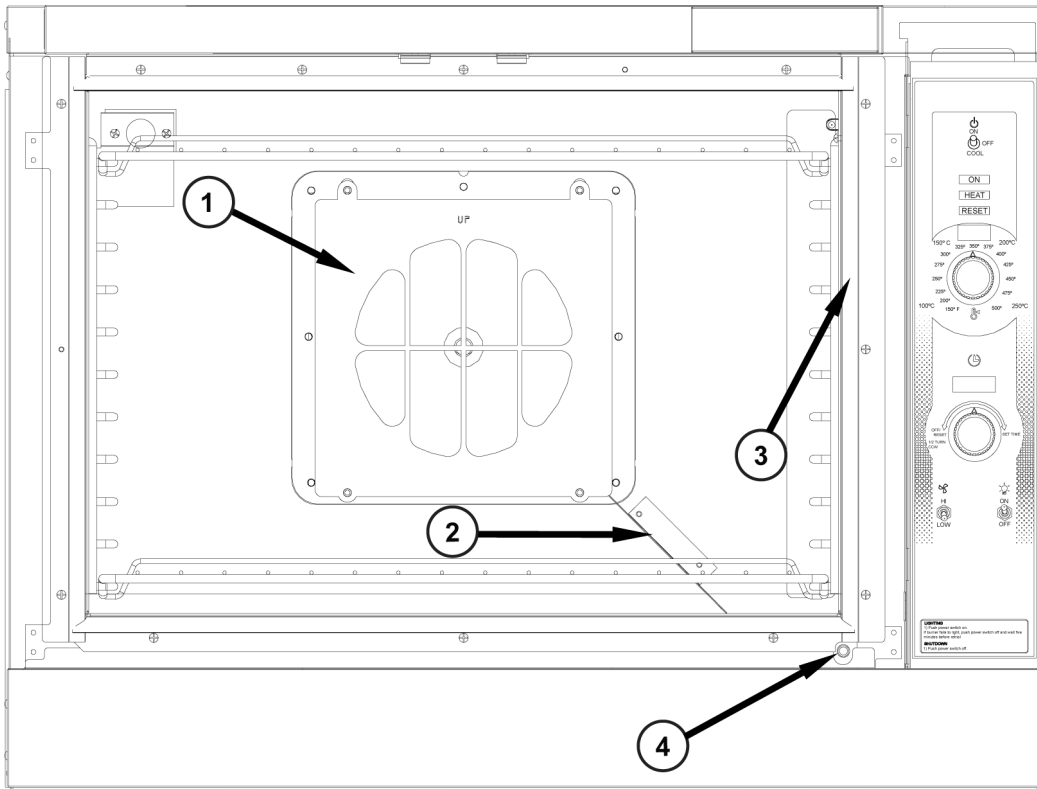

Fig. 47

CONTROL PANEL DIGITAL TIME READOUT



Fig. 48



AI4064

Fig. 49

OVEN CAVITY	
1	Blower Plate and Fan
2	Baffle
3	Door Seal
4	Door Switch

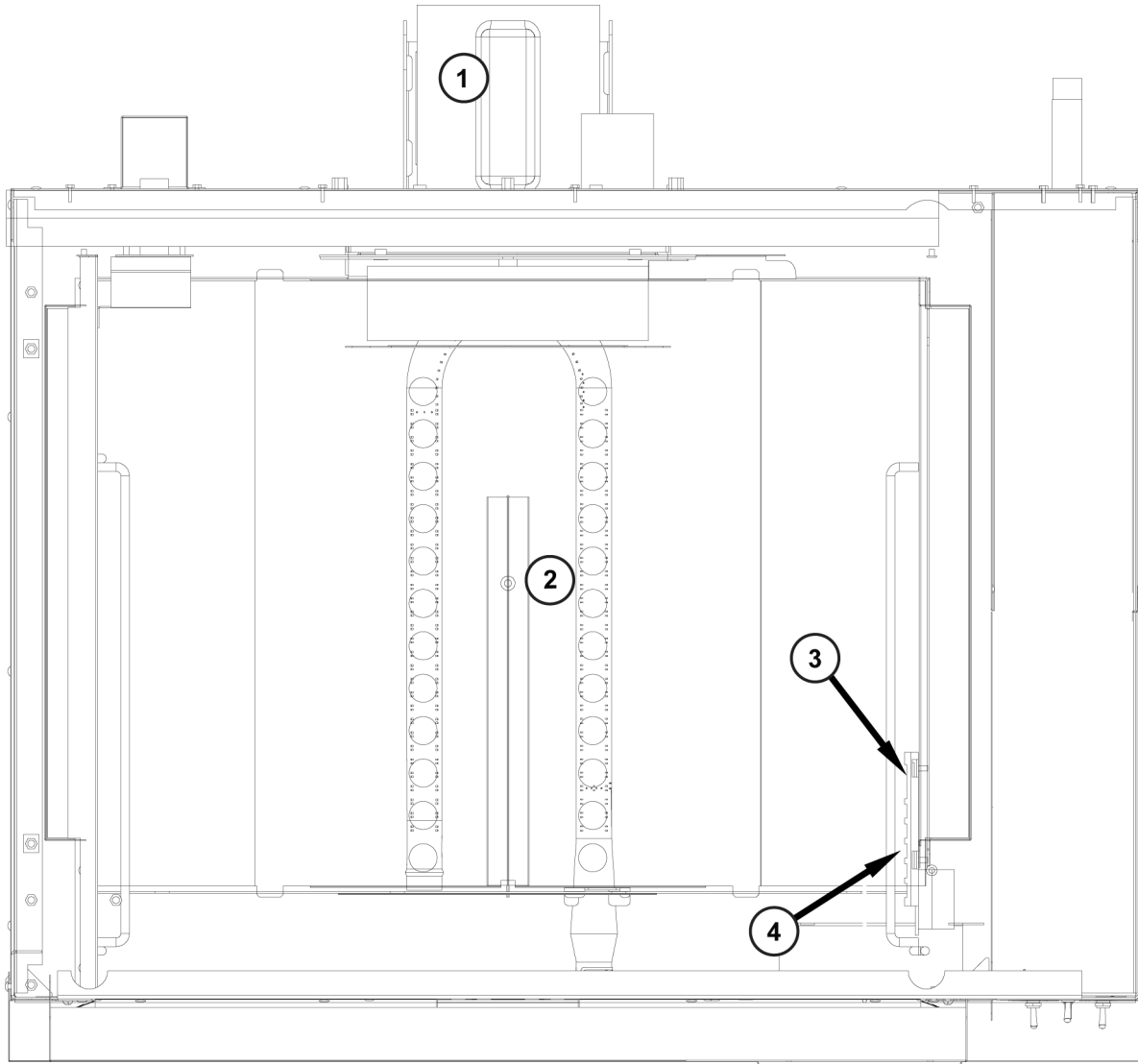

A14065

Fig. 50

TOP VIEW INSIDE OVEN	
1	Blower Motor
2	Burner Assembly and Gas Lines (underneath lower oven cavity)
3	Temperature Probe
4	Light

### SEQUENCE OF OPERATION

#### Cook Cycle

1. Conditions.

- A. Oven connected to correct voltage and is properly grounded.
- B. Power switch (S1) OFF.

- C. Temperature dial set to lowest temperature (fully Counter-Clockwise).
- D. High limit thermostat CLOSED.
- E. Oven doors closed (door switch contacts CLOSED).
- F. Oven cavity temperature below 140°F.

2. Set temperature control dial to desired temperature.
3. Power switch (S1) turned ON.
  - A. Component cooling fan energized.
  - B. Power ON light (Amber) comes ON.

**NOTE:** Power is available to oven light switch to turn oven cavity lights ON when light switch is turned ON; and power is available to normally open (N.O.) side of door switch contacts and connects power to additional components when door switch contacts are CLOSED (door closed).

4. Transformer (T1) energized.
  - A. Power (24VAC) to one side of the following components: high limit --- connected through normally closed (N.C.) contacts to First valve (safety) on the dual solenoid gas valve.
    - 1) 1st valve (safety) on gas valve energized.

**NOTE:** Gas does not flow to the burner until Second valve (main) is energized.

- B. With door switch closed, power is applied to motor speed (Hi/Low).
  - 1) Power is connected through function switch (S3) contacts and convection fan motor is energized (fan speed hi).
  - 2) Power to normally open (N.O.) side of internal relay contacts on temperature control board.
  - 3) When convection fan motor reaches operating speed, the centrifugal switch (N.O.) on motor closes.
  - 4) Solid state temperature control energized. If the oven temperature is below set point, the temperature control will energize its internal relay. The normally open (N.O.) contacts close and apply power to the following components:
    - a. Heat light (clear) comes ON.
    - b. Power is connected through the centrifugal switch contacts on the convection fan motor, heat relay is energized, contacts (N.O.) close and the heating circuit is powered.
    - c. Ignition control module is energized.

- d. Second valve (main) on gas valve is energized. Gas starts to flow to burner, sparking begins, the burner lights. Sparking continues for up to 7 seconds or until a flame is established. If a flame is "sensed", the "no ignition" light stays out and burner remains lit. If a flame is not "sensed" after 7 seconds of sparking, "no ignition" light comes on, Second valve (main) on the gas valve is de-energize and gas flow to burner stops. Ignition trial cycle repeats after a 15 second purge between cycles for two additional tries before locking out. To reset after a lockout, turn power switch (S1) OFF then ON.

5. Oven reaches set temperature.
  - A. Temperature control de-energizes internal relay and the normally open (N.O.) contacts OPEN.
    - 1) Heat light goes out.
    - 2) Power removed from heat relay.
      - a. Power removed from Second valve (main) on gas valve and gas flow to burner stops.
6. Oven will continue to cycle on temperature control until doors are opened or power switch (S1) is turned to OFF or COOL DOWN position.

#### Timer Cycle, Cooking

**NOTE:** "Cook" timer operates independently of heating cycle. Additional time can be set or timer can be turned OFF throughout cooking cycle.

1. With power switch turned ON, power is supplied to "Cook" timer terminal 1.
2. Set "Cook" timer to desired time.
  - A. Contacts 1 & 3 close, timer motor is energized and timing "down" begins.
3. Time expires on "Cook" timer.
  - A. Contacts 1 & 3 open, timer motor is de-energized and timing stops.
  - B. Contacts 1 & 4 close.
    - 1) Buzzer energized and sounds.

**NOTE:** The buzzer continues to sound until the timer dial is set to the OFF position or additional time is set.

#### Cool Down Cycle



1. Conditions.
  - A. Oven is ON.
  - B. Oven cavity temperature needs to be lowered.
  - C. Doors are open (door switch contacts OPEN).
  - D. Fan speed switch (S2) set to "Hi".
2. Power Switch (S1) turned to COOL DOWN.
  - A. Power ON light (Amber) goes out.
  - B. Convection fan motor energized.
3. If doors are CLOSED (door switch contacts CLOSED):
  - A. Power ON light (Amber) comes ON.
  - B. Component cooling fan energized.
  - C. Power is supplied to:
    - 1) "Cook" timer terminal 1. If a time is dialed, timer will operate and buzzer will sound when timer reaches zero.
    - 2) Oven cavity light switch (S3) wire #1. Turns cavity lights ON/OFF; does not affect Cool down cycle.
4. The oven will remain in this condition until the power switch (S1) is turned off.

# DIAGRAMS

## WIRING DIAGRAM AND SCHEMATIC

---

### 11 x 17 SIZE

#### Before SN 481870195 (Natural Gas) and 481867299 (Propane)

- [VC5GD WIRING DIAGRAM](#)
- [VC5GD SCHEMATIC](#)

#### After SN 481870195 (Natural Gas) and 481867299 (Propane)

- [VC5GD WIRING DIAGRAM](#)
- [VC5GD SCHEMATIC](#)

#### Production after 4/19/18

- [VC5GD WIRING DIAGRAM](#)
- [VC5GD SCHEMATIC](#)

#### Production after 12/14/21, 482010858 (Natural Gas) and 482011010 (Propane)

- [VC5GD WIRING DIAGRAM](#)
- [VCGD SCHEMATIC](#)

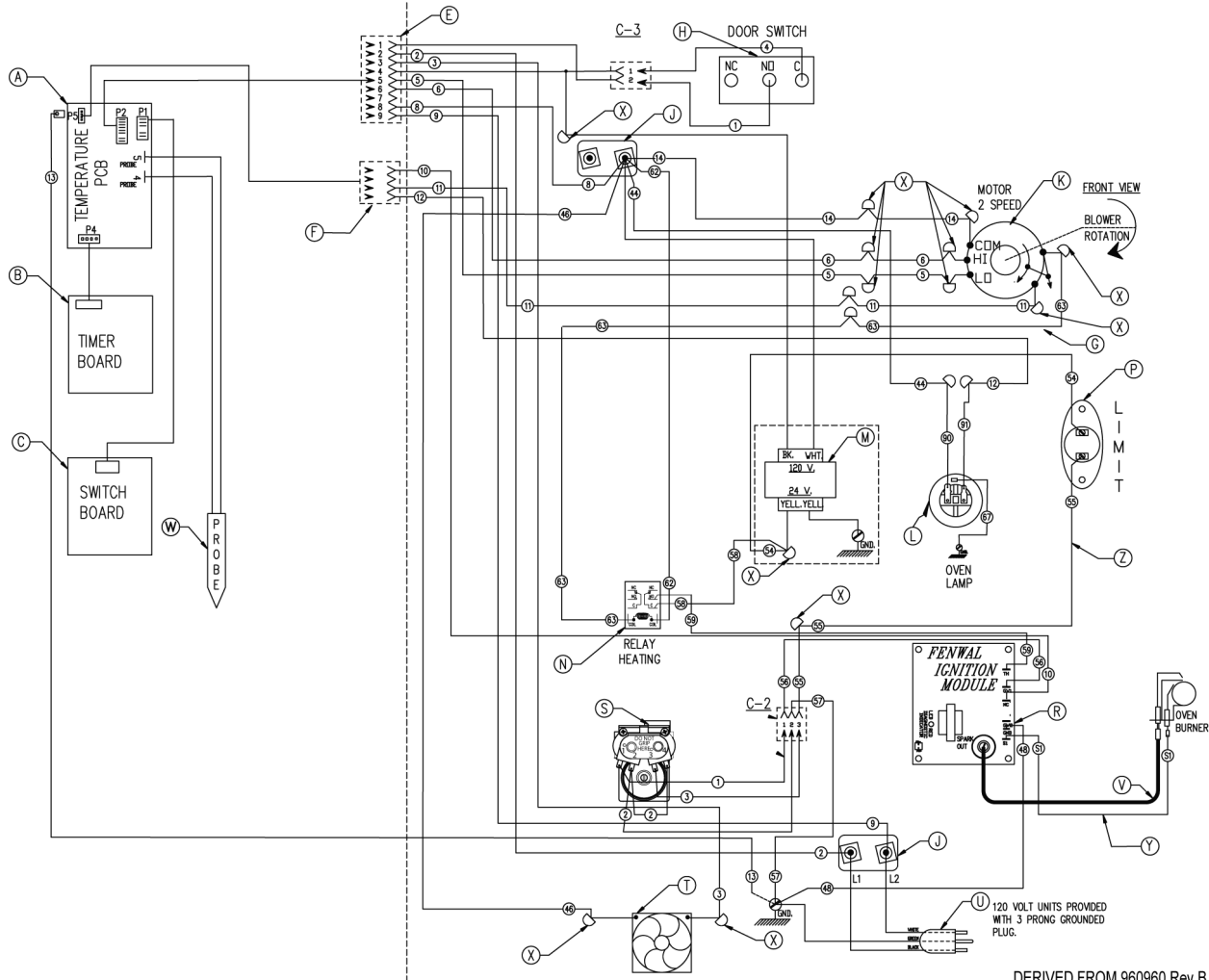

VC5GD-11D1 (Natural Gas Units) Before Serial Number 481870195  
 VC5GD-21D1 (Propane Units) Before Serial Number 481867299

DERIVED FROM 960960 Rev B  
 VC5GD - WIRING DIAGRAM  
 SEE SCHEMATIC DECAL 960985-1

**AI4060**

**VC5GD GAS CONVECTION OVEN WIRING DIAGRAM BEFORE SN 481870195 (Natural Gas) and 481867299 (Propane)**

<b>LEGEND FOR VC5GD GAS CONVECTION OVEN WIRING DIAGRAM BEFORE SN 481870195 (Natural Gas) and 481867299 (Propane)</b>	
A	ASSY, TEMP. CONTROL BOARD
B	ASSY, TIMER BOARD
C	ASSY, SWITCH BOARD
D	REAR WIRED SET (SEE NOTE)
E	ACTUATOR HARNESS
F	SENSING HARNESS
G	MOTOR WIRE SET
H	DOOR SWITCH, 2HP, 250F
J	BLOCK, PORCELAIN ASSEMBLY

**LEGEND FOR VC5GD GAS CONVECTION OVEN WIRING DIAGRAM BEFORE SN 481870195 (Natural Gas) and 481867299 (Propane)**

K	MOTOR 2 SPEED G.E.
L	BJB LIGHT, 120V
M	TRANSFORMER 24V. OUT
N	RELAY , HEATING
P	OVEN, LIMIT ASSEMBLY COMPLETE
R	CONTROL, SPARK IGNITION
S	MAXITROL CONVERTABLE VALVE
T	FAN, COOLING
U	CORD SET 120V. UNITS ONLY
V	WIRE, SPARK IGNIT. 36"
W	PROBE, THERMISTOR
X	WIRE NUT, BLUE
Y	WIRE ASSY, S1
Z	OVEN, LIMIT HARNESSSES (54,55)

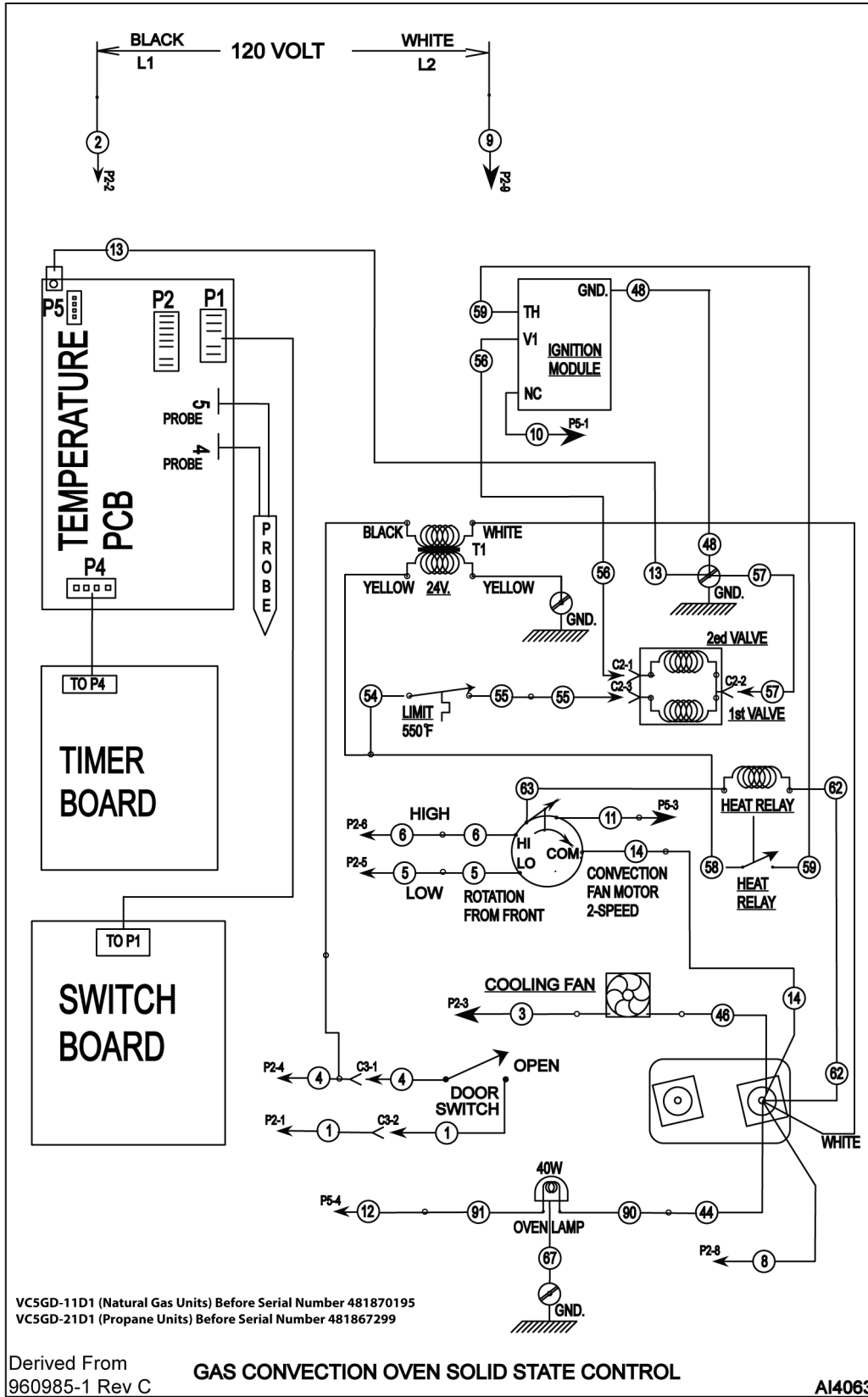

VC5GD GAS CONVECTION OVEN SCHEMATIC BEFORE SN 481870195 (Natural Gas) and 481867299 (Propane)

FULL SIZE GAS CONVECTION OVEN - DIAGRAMS

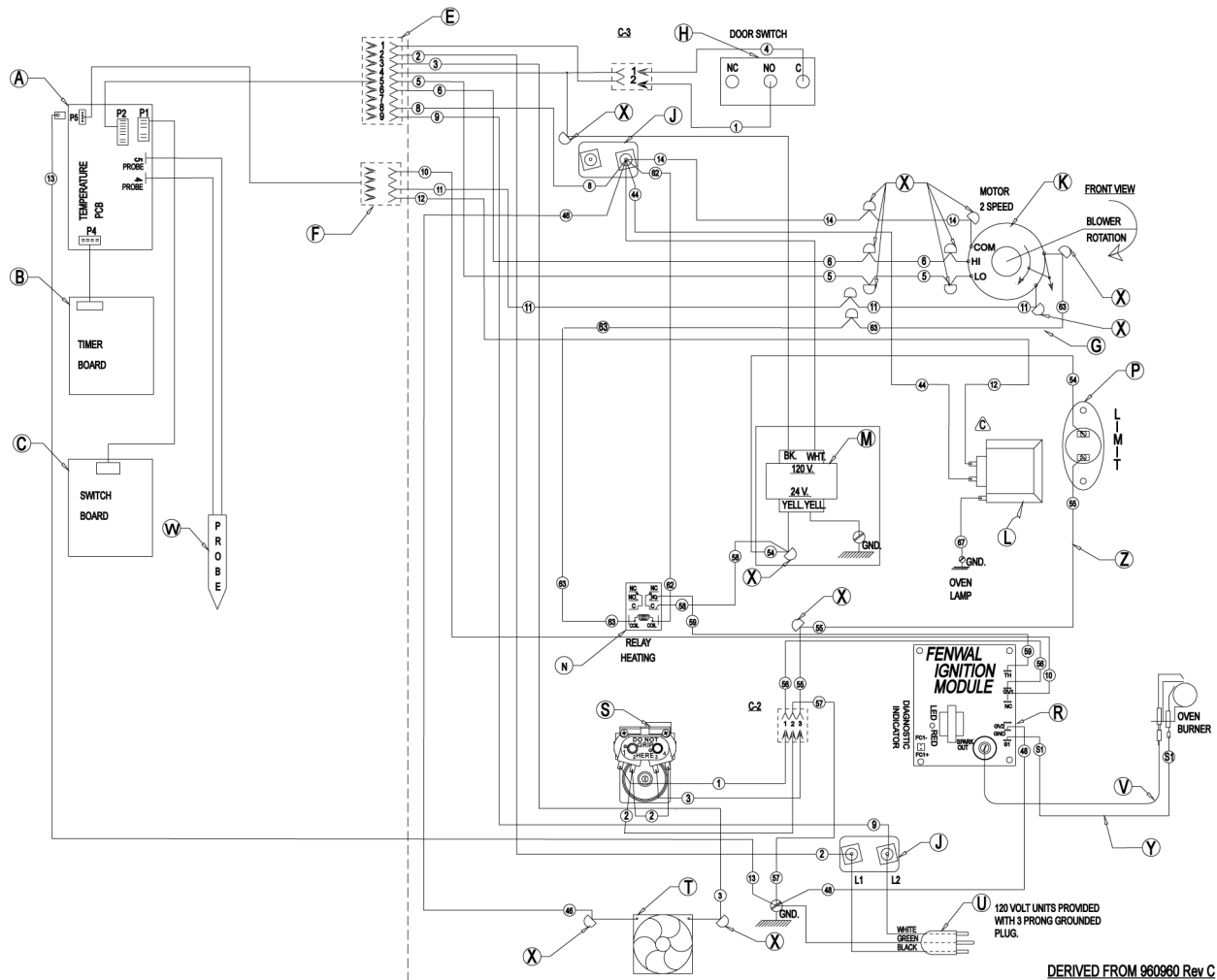

VC5GD-11D1 (Natural Gas Units) After SN 481870195  
 VC5GD-21D1 (Propane Units) After Serial Number 481867299

DERIVED FROM 960960 Rev. C  
 VC5GD - WIRING DIAGRAM  
 SEE SCHEMATIC DECAL 960985-1  
 A14087

**VC5GD WIRING DIAGRAM AFTER SN 481870195 (Natural Gas) and 481867299 (Propane)**

<b>LEGEND FOR VC5GD WIRING DIAGRAM AFTER SN 481870195 (Natural Gas) and 481867299 (Propane)</b>	
A	ASSY, TEMP. CONTROL BOARD
B	ASSY, TIMER BOARD
C	ASSY, SWITCH BOARD
D	REAR WIRED SET (SEE NOTE)
E	ACTUATOR HARNESS
F	SENSING HARNESS
G	MOTOR WIRE SET
H	DOOR SWITCH, 2HP, 250F
J	BLOCK, PORCELAIN ASSEMBLY
K	MOTOR 2 SPEED G.E.
L	BJB LIGHT, 120V
M	TRANSFORMER 24V. OUT
N	RELAY, HEATING

<b>LEGEND FOR VC5GD WIRING DIAGRAM AFTER SN 481870195 (Natural Gas) and 481867299 (Propane)</b>	
P	OVEN, LIMIT ASSEMBLY COMPLETE
R	CONTROL, SPARK IGNITION
S	MAXITROL CONVERTABLE VALVE
T	FAN, COOLING
U	CORD SET 120V. UNITS ONLY
V	WIRE, SPARK IGNIT. 36"
W	PROBE, THERMISTOR
X	WIRE NUT, BLUE
Y	WIRE ASSY, S1
Z	OVEN, LIMIT HARNESSSES (54,55)

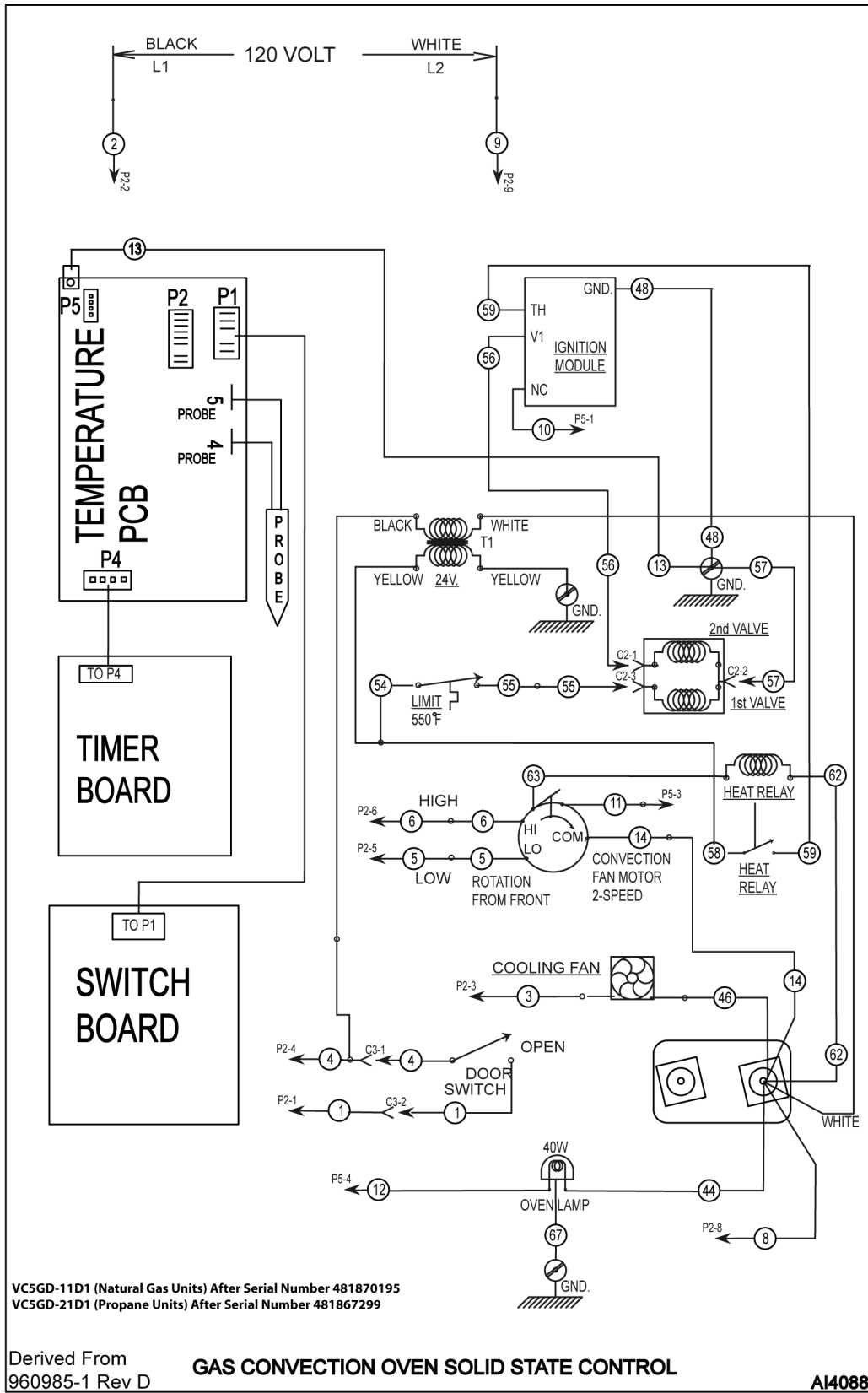

VC5GD SCHEMATIC AFTER SN 481870195 (Natural Gas) and 481867299 (Propane)



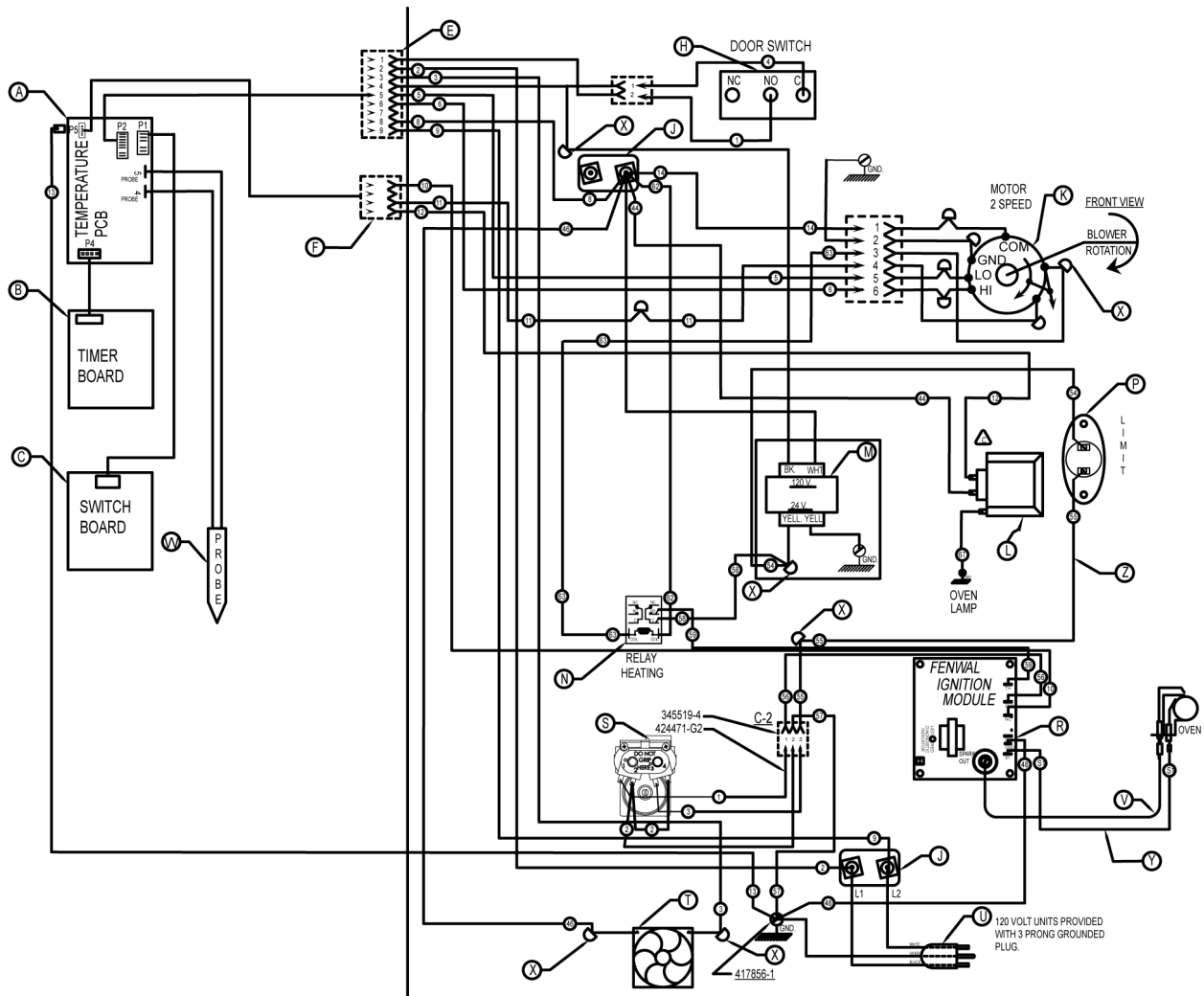

DERIVED FROM WIRE DIAGRAM 960960-1 Rev. E

AI4887

**VC5GD GAS CONVECTION OVEN WIRING DIAGRAM - Production after 4/19/18**

<b>LEGEND FOR VC5GD GAS CONVECTION OVEN WIRING DIAGRAM - Production after 4/19/18</b>	
A	ASSY, TEMP. CONTROL BOARD
B	ASSY, TIMER BOARD
C	ASSY, SWITCH BOARD
D	REAR WIRED SET (SEE NOTE)
E	ACTUATOR HARNESS
F	SENSING HARNESS
G	MOTOR WIRE SET
H	DOOR SWITCH, 2HP, 250F
J	BLOCK, PORCELAIN ASSEMBLY
K	MOTOR 2 SPEED G.E.
L	BJB LIGHT, 120V
M	TRANSFORMER 24V. OUT
N	RELAY , HEATING

<b>LEGEND FOR VC5GD GAS CONVECTION OVEN WIRING DIAGRAM - Production after 4/19/18</b>	
P	OVEN, LIMIT ASSEMBLY COMPLETE
R	CONTROL, SPARK IGNITION
S	MAXITROL CONVERTABLE VALVE
T	FAN, COOLING
U	CORD SET 120V. UNITS ONLY
V	WIRE, SPARK IGNIT. 36"
W	PROBE, THERMISTOR
X	WIRE NUT, BLUE
Y	WIRE ASSY, S1
Z	OVEN, LIMIT HARNESSSES (54,55)

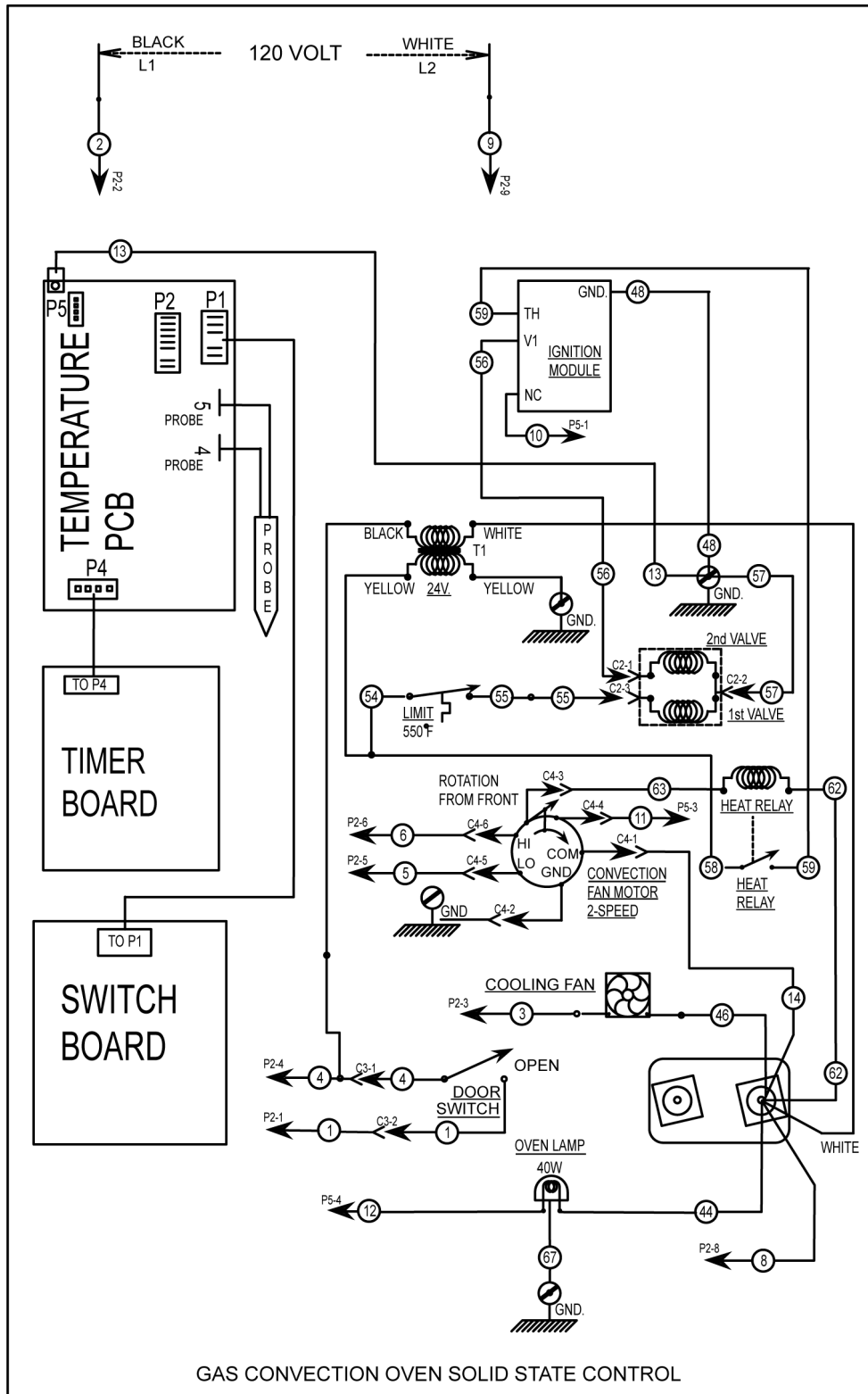

GAS CONVECTION OVEN SOLID STATE CONTROL

DERIVED FROM WIRE DIAGRAM 960985-1 Rev. E

AI4886

VC5GD SCHEMATIC - Production after 4/19/18

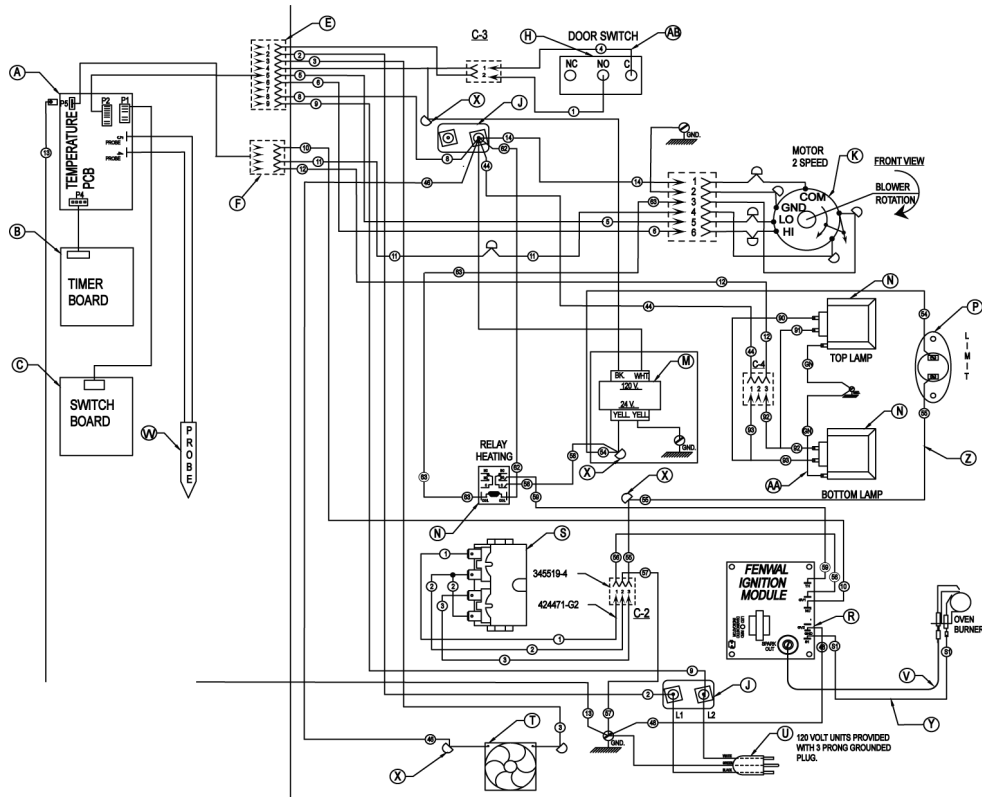

SEE SCHEMATIC DECAL 962499-1  
 FULL SIZE GAS, 120V WIRING DIAGRAM

DERIVED FROM 962503

AI5301

**VC5GD GAS CONVECTION OVEN WIRING DIAGRAM - Production after 12/14/2021**

**LEGEND FOR Fig. 57**

A	ASSY, TEMP. CONTROL BOARD
B	ASSY, TIMER BOARD
C	ASSY, SWITCH BOARD
D	REAR WIRED SET (SEE NOTE)
E	ACTUATOR HARNESS
F	SENSING HARNESS
H	DOOR SWITCH, 2HP, 250F
J	BLOCK, PORCELAIN ASSEMBLY
K	MOTOR 2 SPEED G.E.
L	BJB LIGHT, 120V
M	TRANSFORMER 24V. OUT
N	RELAY, HEATING
P	OVEN, LIMIT ASSEMBLY COMPLETE
R	CONTROL, SPARK IGNITION
S	MAXITROL CONVERTABLE VALVE
T	FAN, COOLING

<b>LEGEND FOR Fig. 57</b>	
U	CORD SET 120V. UNITS ONLY
V	WIRE, SPARK IGNIT. 36"
W	PROBE, THERMISTOR
X	WIRE NUT, BLUE
Y	WIRE ASSY, S1
Z	OVEN, LIMIT HARNESSSES (54,55)
AA	WIRE SET, LIGHTS, GND
AB	DOOR SW HARNESS

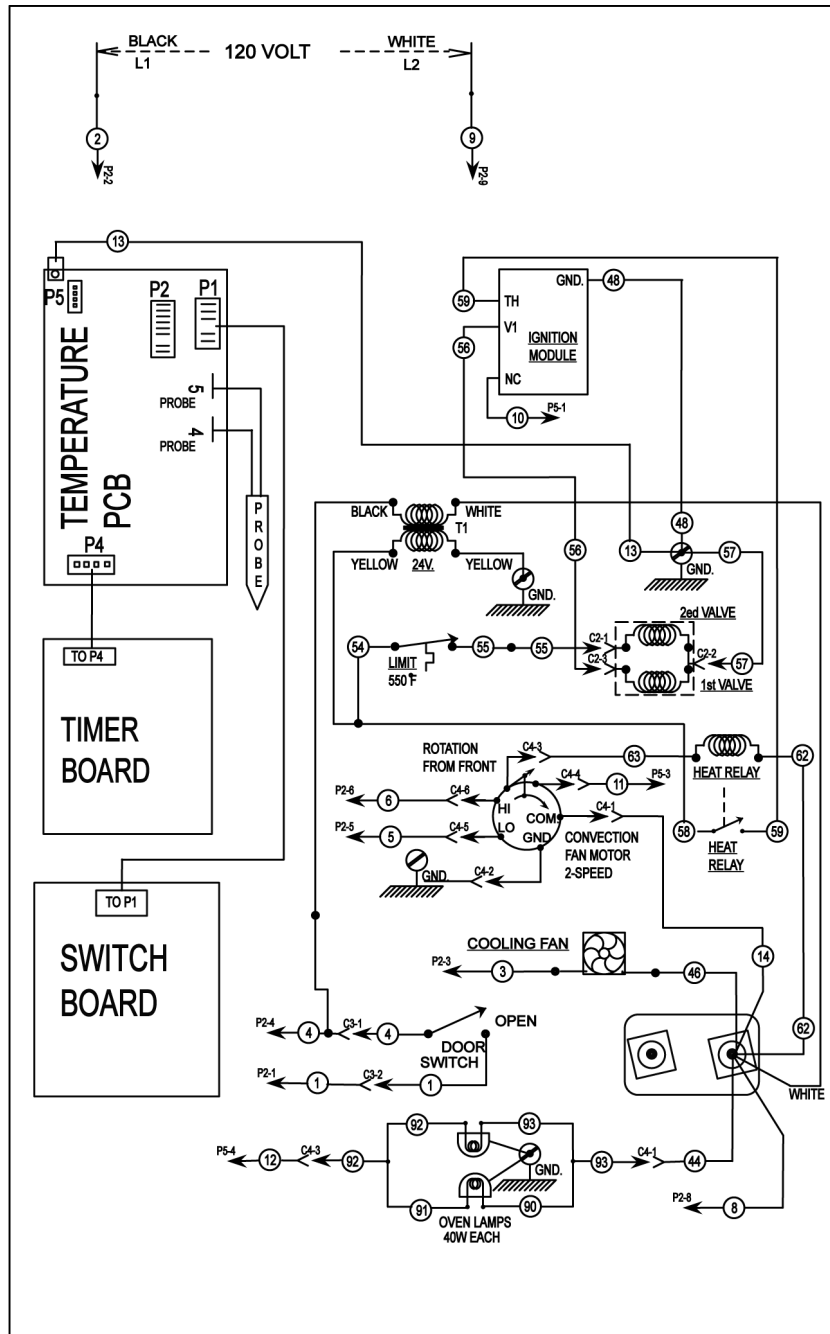

**GAS CONVECTION OVEN SOLID STATE CONTROL - VC5G SCHEMATIC**

**SINGLE BURNER CONVECTION OVEN 120 & 200 V.**

**DERIVED FROM 962499-1 Rev B**

AI5304

**VC5GD GAS CONVECTION OVEN SCHEMATIC - Production after 12/14/2021**

# TRUBLESHOOTING

## ERROR CODES

**⚠ WARNING**

Before attempting corrective action lockout tag out must be done.



**⚠ WARNING**

Disconnect the electrical power to the machine and follow lockout / tagout procedures.

**NOTE:** Error codes will be on temp display as well as the blink code from the LED on back of board.



Fig. 59

ERROR MESSAGE	ERROR	ACTION
1	OPEN TEMPERATURE PROBE	<ol style="list-style-type: none"> <li>Temperature probe failure.</li> <li>Temperature control board failure.</li> </ol>
2	SHORTED TEMPERATURE PROBE	<ol style="list-style-type: none"> <li>Temperature probe failure.</li> <li>Temperature control board failure.</li> </ol>

ERROR MESSAGE	ERROR	ACTION
3	<p>NO TEMPERATURE INCREASE</p> <p><b>NOTE:</b> This means the oven has been calling for heat for 8 minutes and the temperature control board has not measured an increased.</p>	<p><b>If burner is on and running properly:</b></p> <ol style="list-style-type: none"> <li>1. Temperature control board failure.</li> </ol> <p><b>If burner is not on:</b></p> <ol style="list-style-type: none"> <li>1. Relay failure.</li> <li>2. 24V transformer failure.</li> <li>3. Motor/Centrifugal switch failure.</li> <li>4. Temperature control board failure.</li> <li>5. Ignition board failure.</li> </ol>
4	<p>PCB OVERHEAT</p> <p><b>NOTE:</b> This means temperature control board is experiencing temperatures above its rated limit. This can reduce the life of oven control components</p>	<ol style="list-style-type: none"> <li>1. Clogged rear air intake.</li> <li>2. Cooling fan failure.</li> </ol>
5	NO OUTPUT	<ol style="list-style-type: none"> <li>1. Temperature control board failure.</li> </ol>
6	OUTPUT SHORTED	<ol style="list-style-type: none"> <li>1. Temperature control board failure.</li> </ol>
7	NO HEAT SIGNAL FROM IGNITION BOARD	<ol style="list-style-type: none"> <li>1. Problem with gas supply/gas valve.</li> <li>2. Ignitor failure/ improper spark gap.</li> <li>3. Flame sensor failure.</li> <li>4. Ignition board failure.</li> <li>5. Temperature control board failure.</li> <li>6. High Limit is open.</li> </ol>
CLN	CONTROLLER OVERHEAT	<ol style="list-style-type: none"> <li>1. Clean rear air intake.</li> </ol>

**ALL MODELS**





**⚠ WARNING**

**Certain procedures in this section require electrical test or measurements while power is applied to the machine. Exercise extreme caution at all times and follow Arc Flash procedures. If test points are not easily accessible, disconnect power and follow Lockout/Tagout procedures, attach test equipment and reapply power to test.**

SYMPTOMS	POSSIBLE CAUSES
Blower motor doesn't run with 1S in "Cool Down" or "On" position.	<ol style="list-style-type: none"> <li>1. Line voltage.</li> <li>2. Power switch (S1) malfunction.</li> <li>3. Switch (S3) malfunction.</li> <li>4. Interconnecting wiring malfunction.</li> <li>5. Motor inoperable.</li> </ol>
Blower motor doesn't run in "On" position. "Cool Down" functions OK.	<ol style="list-style-type: none"> <li>1. Door switch malfunction.</li> <li>2. Power switch contacts inoperative.</li> <li>3. Interconnecting wiring malfunction.</li> </ol>
Blower motor doesn't run in "Cool Down" position. Runs OK in "On" position.	<ol style="list-style-type: none"> <li>1. Power switch malfunction.</li> <li>2. Interconnecting wiring malfunction.</li> </ol>
Gas does not ignite; No spark; RESET Light ON.	<ol style="list-style-type: none"> <li>1. Shorted electrode on ignitor/flame sense.</li> <li>2. Ignitor cable (high voltage) OPEN.</li> <li>3. Heat relay malfunction.</li> <li>4. Transformer inoperative.</li> <li>5. High limit thermostat open.</li> <li>6. Interconnecting wiring malfunction.</li> <li>7. Ignition Module malfunction.</li> <li>8. Temperature probe malfunction.</li> </ol>
Sparks but gas does not ignite.	<ol style="list-style-type: none"> <li>1. Gas solenoid valve OFF or inoperative.</li> <li>2. Manual gas valve CLOSED.</li> <li>3. Gas supply OFF or Insufficient gas pressure.</li> <li>4. Interconnecting wiring malfunction.</li> <li>5. Ignition Module malfunction.</li> </ol>
Gas ignites but will not maintain flame.	<ol style="list-style-type: none"> <li>1. Igniter lead connections malfunction.</li> <li>2. Ignitor ground inoperative.</li> <li>3. Ignitor/flame sense malfunction.</li> <li>4. Insufficient gas pressure.</li> <li>5. Snorkel vent plugged, obstructed or missing.</li> <li>6. Incorrect polarity from transformer to Ignition module.</li> </ol>



**⚠ WARNING**

Certain procedures in this section require electrical test or measurements while power is applied to the machine. Exercise extreme caution at all times and follow Arc Flash procedures. If test points are not easily accessible, disconnect power and follow Lockout/Tagout procedures, attach test equipment and reapply power to test.

SYMPTOMS	POSSIBLE CAUSES
Excessive or low heat.	<ol style="list-style-type: none"> <li>1. Temperature probe malfunction.</li> <li>2. Temperature control board malfunction.</li> <li>3. Gas pressure Insufficient.</li> <li>4. Gas orifice plugged or obstructed.</li> </ol>
Mechanical Timer inoperative or not functioning properly.	<ol style="list-style-type: none"> <li>1. Interconnecting wiring malfunction.</li> <li>2. Line voltage incorrect.</li> <li>3. Timer malfunction.</li> </ol>
Component cooling Fan does not run.	<ol style="list-style-type: none"> <li>1. Motor inoperable.</li> <li>2. Interconnecting wiring malfunction.</li> </ol>
Uneven Cooking.	<ol style="list-style-type: none"> <li>1. Convection Fan motor speed/direction.</li> <li>2. Poor combustion.                             <ol style="list-style-type: none"> <li>A. Gas pressure incorrect.</li> <li>B. Exhaust vent plugged or obstructed.</li> <li>C. Snorkel Vent plugged or obstructed.</li> </ol> </li> <li>3. Air flow Baffles missing or damaged.</li> <li>4. Doors out of adjustment.</li> <li>5. Door roller out of adjustment or broken.</li> <li>6. Door seals damaged.</li> </ol>
Intermittent problems.	<ol style="list-style-type: none"> <li>1. High ambient temperatures.</li> <li>2. Wiring connections loose.</li> <li>3. Cooling fan malfunction.</li> </ol>
No power to temperature control.	<ol style="list-style-type: none"> <li>1. Power switch (S1) in "Cool Down".</li> <li>2. Door or door switch open.</li> </ol>
Door does not seal or shut properly	<ol style="list-style-type: none"> <li>1. Doors out of adjustment.</li> <li>2. Door catch roller out of adjustment or broken (independent doors).</li> <li>3. Door seals damaged.</li> </ol>