

Product Specifications

Refrigerated Self-Service Case

Lengths include 1" end panels

MODELS SHOWN: CO47R-QS

W/ CUTAWAY END PANEL

W/ FULL END PANEL



- CO37R-QS 36-1/4"L x 32-5/8"D x 79-5/8"H
- CO47R-QS 47-1/4"L x 32-5/8"D x 79-5/8"H
- CO57R-QS 59-1/4"L x 32-5/8"D x 79-5/8"H
- CO67R-QS 71-1/4"L x 32-5/8"D x 79-5/8"H

STANDARD FEATURES

- Breeze~E (Type-II) w/ EnergyWise s/c refrigeration
- 4"D removable rear wall spacer (not included in depth dimensions)
- 6' power cord (base exit)
- Compressor air front intake, rear discharge. Front panel cannot be blocked. Must remain 4" from wall
- Condensate pan (self-contained refrig. only)
- Integrated average product temperature of 40°F or less
- One year parts & labor; 5 year compressor warranty
- Removable deck pans provide complete access to evaporator coil & refrigeration connections
- Shelving removable and adjustable on 1" centers
- T-8 top light(s)

Features	Standard	Options
EXTERIOR COLOR	<input type="checkbox"/> Laminated (non-premium) Confirm pattern/grain direction	<input type="checkbox"/> Laminated (premium) Confirm pattern/grain direction
INTERIOR COLOR	<input type="checkbox"/> Black	
LWR LOUVERED FRNT PANEL	<input type="checkbox"/> Painted - Black	
BASE	<input type="checkbox"/> Casters (n/a with remote)	
END PANEL LEFT	<input type="checkbox"/> Full end panel w/mirror interior	
END PANEL RIGHT	<input type="checkbox"/> Full end panel w/mirror interior	
EXTERIOR BACK PANEL	<input type="checkbox"/> Solid back panel, black	
SHELVING	<input type="checkbox"/> Metal shelves, non-lighted	<input type="checkbox"/> Metal shelves, lighted (T-8)
REFRIGERATION	<input type="checkbox"/> Breeze~E (Type-II) w/ EnergyWise s/c refrigeration	
MISCELLANEOUS		<input type="checkbox"/> Second year parts & labor warranty (excludes compressor)

Product Specifications

Intended Environment: Type II - Designed to operate in ambient conditions of 80°F and 60% relative humidity unless noted otherwise in system information below.		
Zone	Intended Product To Be Displayed	Integrated Prod Temp ° F
All	Packaged refrigerated products	40

PLAN VIEW

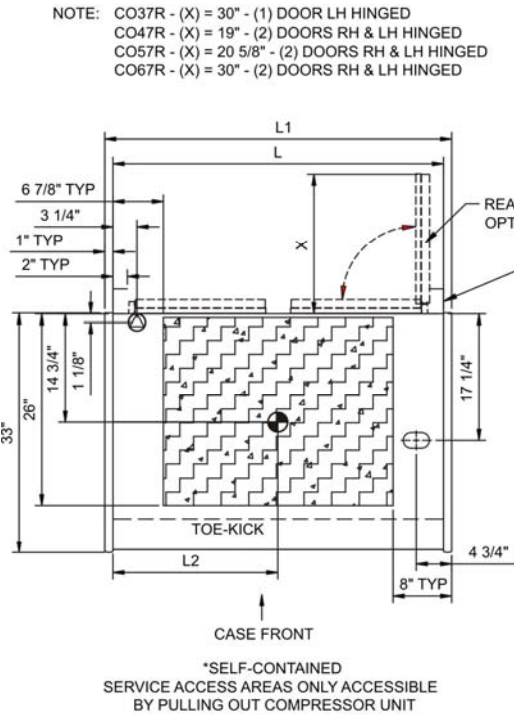

SIDE VIEW

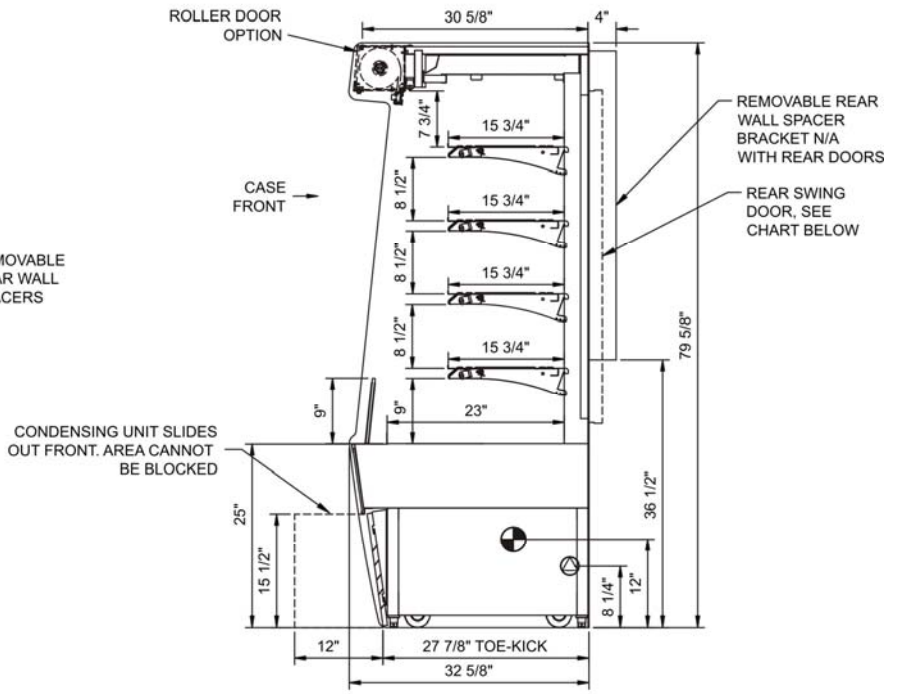

NOTE: ALL DIMENSIONS APPROXIMATE

- ELECTRICAL JUNCTION BOX (SUPPLIED WITH 6" LEADS OR POWER CORD).
- LOCATION OF DRAIN TUBE FOR REMOTE REF. ONLY (SUPPLIED WITH 3/4" OR 1 1/2" PVC TUBE).

- REFRIGERATION LINE CONNECTION.
- REMOTE FLOOR SINK & UTILITIES ACCESS AREA.

- SELF-CONTAINED CASE SERVICE ACCESS AREA.
- DRY CASE SERVICE ACCESS AREA.

Model Technical Specifications

Model	L"	L1"	L2"	System Circuit Volts		Phs	Freq	Amps ***	Watts	Wires	NEMA Plug	SST	BTUH	Ship Wt
CO37R-QS	34.25	36.25	18.00	Self-Contained	Circuit #1	110-120	1	60	15.33	1,480	2+G	N/A	N/A	800
CO47R-QS	45.25	47.25	18.38	Self-Contained	Circuit #1	208-240	1	60	10.23	1,923	2+G	N/A	N/A	1,100
CO57R-QS	57.25	59.25	10.00	Self-Contained	Circuit #1	208-240	1	60	12.00	2,323	2+G	N/A	N/A	1,200
CO67R-QS	69.25	71.25	31.25	Self-Contained	Circuit #1	208-240	1	60	16.00	1,280	2+G	N/A	N/A	1,250

*** Does not include electric defrost on freezer models.

Important Notes:

- 1) ELECTRICAL NOTE: If GFCI is required, a GFCI breaker MUST be used in lieu of a GFCI receptacle
- 2) Performance issues (product temperatures, water on floor, etc.) caused by adverse conditions are not covered by warranty.
- 3) Keep unit at least 15' from exterior doors, overhead HVAC vents, or any air curtain disruption.
- 4) End panels must be tightly joined or kept at least 6" away from any structure to prevent condensation.
- 5) Do not expose unit to direct sunlight or any heat source (ovens, fryers, etc.).
- 6) Keep at least 8" of clearance above unit for air discharge (self-contained only).
- 7) Tile floors, low ceilings, or small rooms will increase noise level. Remote refrigeration recommended.

Regulatory Approvals:

All Models	Accordance with AHRI Std 1200 ETL Listed to UL 471 ETL Listed to CAN/CSA 22.2 No. 120 ETL Sanitation to NSF 7
------------	--



In Accordance with
AHRI Std 1200

DOE 2012
Energy Efficiency
Compliant