



Model: **KR24-MF18** Item #: _____ Date: _____
 Project: _____ Qty: _____ Approved By: _____

18" Liquid CO2 Glass Froster Drainboard Cabinet

Royal Series Underbar



KR24-MF18



CO2 tank sits directly on floor through cutout in cabinet bottom. (CO2 Tank not included)



Built-in Glass Froster unit

Standard Features

- High performance glass froster unit built into front left corner
- 18"W flat top drainboard with removable perforated insert
- Built-in LED light that activates when froster is used
- Cabinet with locking door beneath with cutout for CO2 tank storage
- Includes worktop mounting kit
- Includes 100/240 V AC plug
- Built-in 1" drain
- High quality, stainless steel construction
- CO2 tank not included (20 lb recommended)
- 20 gauge stainless steel backsplash, drainboard, door, and back
- 22 gauge stainless steel sides
- 22 gauge galvanized steel bottom
- 18 gauge stainless steel legs

Specifications

Overall Size	▪ 24" front to back depth x 18" W x 36" H
Drain	▪ 1" drain
Legs	▪ 1-5/8" tubular legs with grey plastic bullet feet
Backsplash	▪ 6-1/2"H x 1-1/2"D
Gas Refrigerant	▪ CO2 (food grade) carbon dioxide
Cylinder Type	▪ CO2 cylinder with siphon tube (not included)
CO2 Line Length	▪ Approx 10 feet (including connection valve)
Power Supply	▪ 100/240V AC plug included ▪ 14V 4A output ▪ Rechargeable 12V battery (not included)
Power Input	▪ 100 - 240V AC
Frequency	▪ 50 - 60 Hz
Max Power Capacity	▪ 50W
Accessories	▪ Worktop mounting kit and battery charger

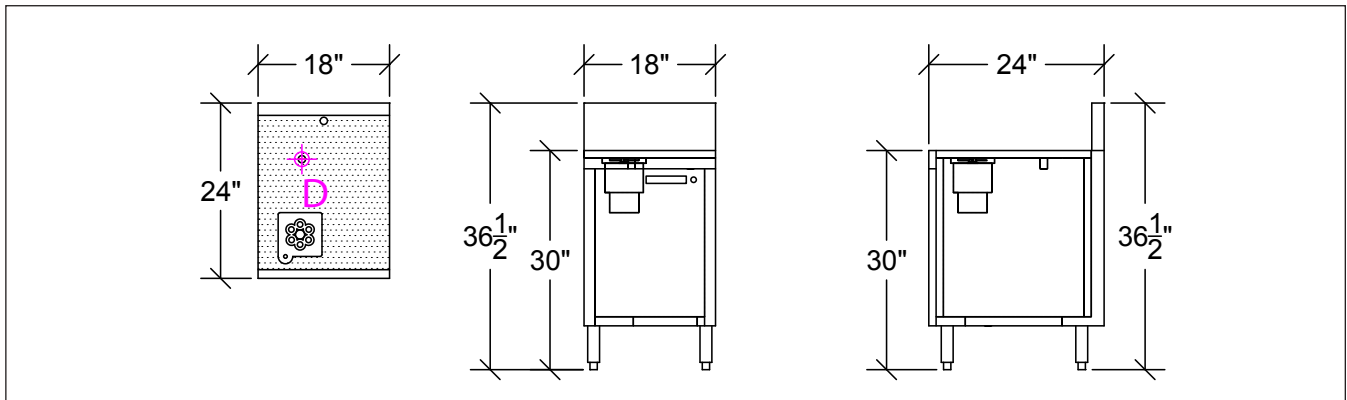

⚠ Warning: This product can expose you to chemicals including lead and lead compounds which are known to the State of California to cause cancer and birth defects or other reproductive harm. For more information go to www.P65Warnings.ca.gov.

Krowne Metal Corporation • 100 Haul Rd. Wayne, NJ 07470 • P: (800) 631-0442 • customerservice@krowne.com • krowne.com

Due to our commitment to continued product improvement, specifications are subject to change without notice.

Rev. 09/2021 • No. KR24-MF18