



PO Box 575 • 2620 Industrial Avenue • Fairbury, Nebraska 68352
Phone: 800-554-7267 • Fax: 402-729-4058 • www.PVIFS.com

Model _____

Quantity _____

Job No. _____

Options Yes _____

Utility Cart

Easily Transport your Supplies with Our Utility Cart!

This two shelf utility cart is the perfect assistant for kitchen staff, cleaning crews, or anyone looking for a mobile work station. Constructed from 12 gauge aluminum, each shelf is adjustable and designed with our new corner clip assembly. An ergonomically designed handle provides comfortable hand placement, improving overall control. Smooth rolling 5" swivel stem casters make maneuverability a breeze and support an overall capacity of 400 pounds. To accommodate every need, this unit is offered in a variety of sizes with optional accessories.



Our Guarantee

- Like all of our American made products, this equipment stand is designed to endure.
- Each item is thoroughly inspected before it's packaged.
- Every unit carries a **Lifetime Guarantee** against rust and corrosion.
- **Three-Year Guarantee** against material defects and workmanship.

We are proud to be one of the leading American manufacturers of food service equipment and ramps. Partnering with us means that we'll solve issues others have failed to address.



This information is for general sales use. Due to continual product improvement, all product details and prices are subject to change without notice.

Model _____

Quantity _____

Job No. _____

Options Yes _____

Aluminum Two Shelf Utility Carts

Knock Down Cart

- Aluminum construction with adjustable shelves & handle
- Smooth, easy clean, solid shelves
- Easy corner clip assembly
- 400lb weight capacity
- Includes four 5" swivel stem casters (CV)

Two Shelf Cart

MODEL NO.	DIMENSIONS (WxHxL)	WEIGHT (LBS)
AUC1824	18" X 36" X 24"	26
AUC1836	18" X 36" X 36"	33
AUC1848	18" X 36" X 48"	37
AUC2024	20" X 36" X 24"	27
AUC2036	20" X 36" X 36"	36
AUC2048	20" X 36" X 48"	38
AUC2424	24" X 36" X 24"	32
AUC2430	24" X 36" X 30"	38
AUC2436	24" X 36" X 36"	40
AUC2448	24" X 36" X 48"	42

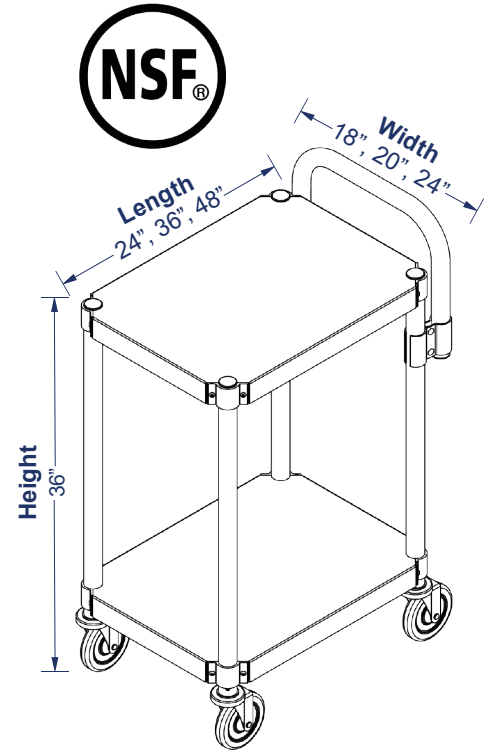

Optional Accessories

Stainless Top

MODEL NO.	DIMENSIONS (WxL)	COMPATIBLE MODELS
1824ST	18" X 24"	AUC1824 & AUC1824-3
1836ST	18" X 36"	AUC1836 & AUC1836-3
1848ST	18" X 48"	AUC1848 & AUC1848-3
2024ST	20" X 24"	AUC2024 & AUC2024-3
2036ST	20" X 36"	AUC2036 & AUC2036-3
2048ST	20" X 48"	AUC2048 & AUC2048-3
2424ST	24" X 24"	AUC2424 & AUC2424-3
2430ST	24" X 30"	AUC2430 & AUC2430-3
2436ST	24" X 36"	AUC2436 & AUC2436-3
2448ST	24" X 48"	AUC2448 & AUC2448-3

Optional Stainless Steel Top

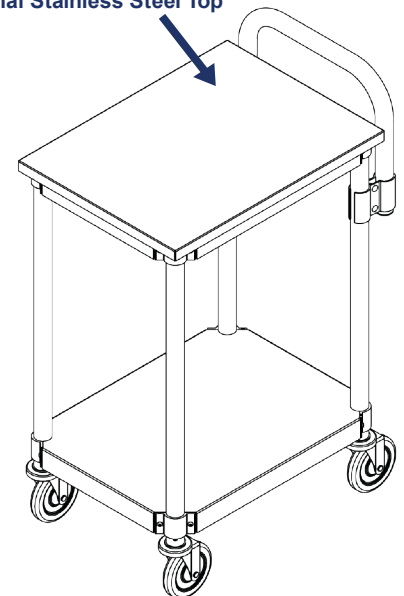

Caster Kits

MODEL NO.	PRODUCT
CL2	Two Swivel & Two Locking Stem Casters
CL4	Four Locking Stem Casters
CHV4	Four Heavy Duty Swivel Stem Casters
CHL2	Two Heavy Duty Swivel & Two Heavy Duty Locking Stem Casters
CHL4	Four Heavy Duty Locking Stem Casters

