

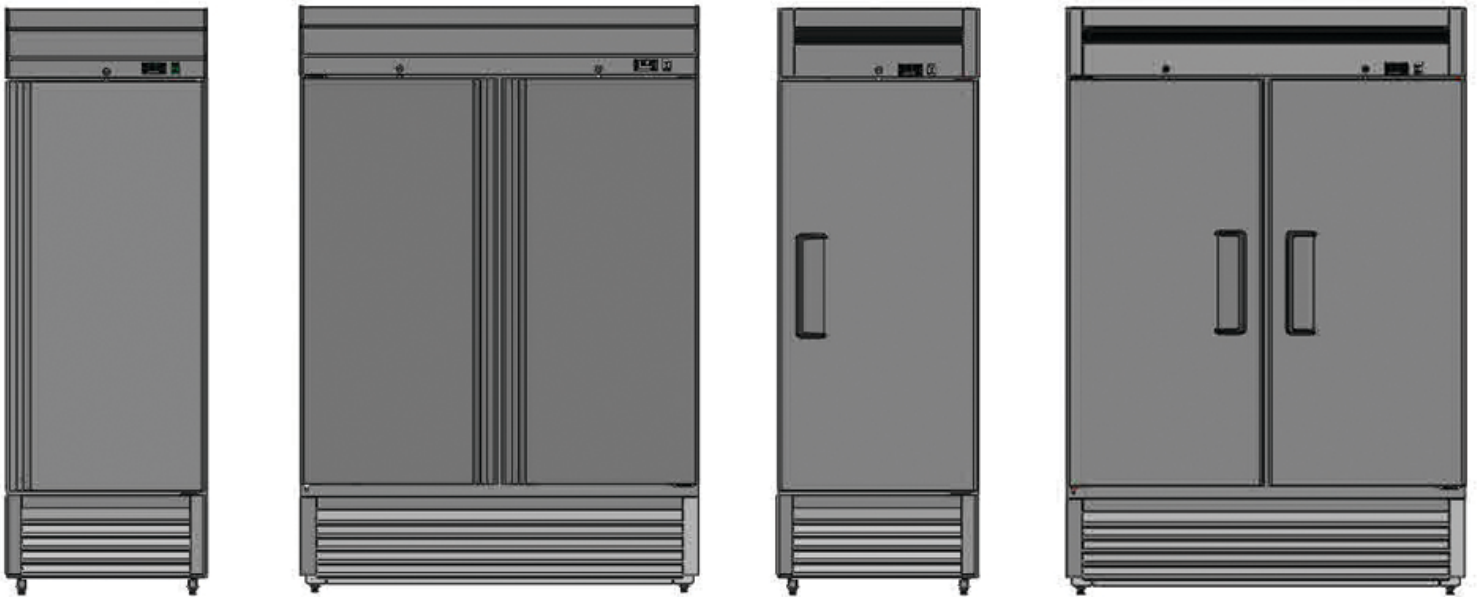

SERVICE, INSTALLATION AND INSTRUCTION MANUAL



68K-765HC, 68K-774HC
69K-889HC, 69K-890HC
REACH-IN FREEZER

PLEASE READ CAREFULLY

TABLE of CONTENTS

INTRODUCTION	2
SERIAL NUMBER INFORMATION	3
RECEIVING AND INSPECTING THE EQUIPMENT	4
APPLIANCE SAFETY.....	4
IMPORTANT SAFEGUARDS.....	5
Electrical Connection.....	6
Refrigerant Disposal	6
Appliance Disposal	6
APPLIANCE INSTALLATION	7
Remove Packaging Materials	7
Location Requirements	7
Inside cabinet:	7
Outside cabinet:	7
Installation Clearance.....	8
Leveling	8
Stabilizing	8
Electrical Connection.....	8
OPERATION	9
Refrigerated cycle	9
Power Switch:	9
SOLID-STATE THERMOSTAT DESCRIPTIONS.....	9
1. FRONT PANEL COMMANDS.....	9
2. MAIN FUNCTIONS	10
3. ALARM SIGNALLING	10
TIPS FOR PROPER OPERATION, CLEANING AND MAINTENANCE	11
CLEANING AND MAINTENANCE	12
Exterior and Interior Cleaning of Appliances	12
Cleaning the Condenser Coil	12
Stainless Steel Care and Cleaning.....	13
Gasket Maintenance.....	13
Doors/Hinges	13
Drain Maintenance.....	13
TROUBLESHOOTING GUIDE.....	14
TROUBLESHOOTING CHART	14
SERVICE AND TROUBLESHOOTING TIPS	15
DIMENSIONS AND TECHNICAL INFORMATION.....	16
COMPONENT INFORMATION.....	17
REFRIGERATION DIAGRAM	17
WIRING DIAGRAMS	18
PARTS.....	19

INTRODUCTION

This user's manual is intended for installing, using and servicing your Argus appliance. It is recommended that this manual be kept in an accessible place. Every Argus machine is designed and manufactured according to the highest standards of safety and performance. It meets or exceeds UL 471 safety standards and sanitation standard NSF 7.

Argus assumes no liability or responsibility of any kind for products manufactured by Argus that have been altered in any way, including the use of any parts and/or other components not specifically approved by Argus. Argus reserves the right to make design changes and/or improvements at any time. Specifications and designs are subject to change without notice.

SERIAL NUMBER INFORMATION

- The serial number of all self-contained appliances is located inside the unit on the left hand side near the top on the wall.
- Always have the serial number of your unit available when calling for parts or service.

**READ THIS MANUAL IN ITS ENTIRETY
TO HELP FAMILIARIZE YOURSELF WITH YOUR NEW EQUIPMENT BEFORE PROCEEDING.**
We have provided many important safety messages in this manual.
Always read and obey all safety messages.
Understanding of safety messages will assist in alerting you to potential hazards, as well as tell you
how to reduce the chance of injury. Follow the instructions as outlined in this manual.

Due to periodic changes in designs, methods, procedures, policies and regulations, the contents of this manual are subject to change without notice. While we exercise good faith efforts to provide information that is accurate, we are not responsible for errors or omissions in information provided or conclusions reached as a result of using this reference manual. By using the information provided rather than simply using it for reference purposes, the user assumes all risks in connection with such use.

RECEIVING AND INSPECTING THE EQUIPMENT

Even though most equipment is shipped crated, care should be taken during unloading so the equipment is not damaged while being moved into the building.

1. Visually inspect the exterior of the package and skid or container. Any damage should be noted and reported to the delivering carrier immediately.
2. If the damage appears minor, open and inspect the contents with the carrier. Take photographs of the packaging before its opened. If the carrier is impatient & won't wait, return the goods if the damage appears to be anything more substantial than superficial harming of the external protective packing layers.
3. In the event that the exterior is not damaged, yet upon opening, there is concealed damage to the equipment, notify the carrier. Notification should be made verbally as well as in written form.
4. Request an inspection by the shipping company of the damaged equipment. This should be done within 10 days from receipt of the equipment.
5. Be certain to check the compressor compartment housing and visually inspect the refrigeration package. Be sure lines are secure and base is still intact.
6. Freight carriers can supply the necessary damage forms upon request.
7. Retain all crating material until an inspection has been made or waived.

APPLIANCE SAFETY

Always read and obey all safety messages.



This is the Safety Alert Symbol. This symbol alerts you to potential hazards that can injure or kill you and others. All safety messages will follow the Safety Alert Symbol and either the words “**DANGER**”, “**WARNING**” OR “**CAUTION**”.

DANGER

DANGER means that failure to heed this safety statement may result in Death or Severe Personnel Injury.

WARNING

WARNING means that failure to heed this safety statement may result in extensive product damage, serious personal injury, or death.

CAUTION

CAUTION means that failure to heed this safety statement may result in minor or moderate personal injury, or property or equipment damage.

All safety messages will alert you to what the potential hazard is, tell you how to reduce the chance of injury, and let you know what can happen if the instructions are not followed.



NOTE: IMPORTANT SAFETY INSTRUCTIONS

WARNING

To reduce the risk of fire, electric shock or injury, when using your appliance, follow these basic precautions:

- Plug into grounded 3-prong outlet.
- Do not remove grounding prong.
- Do not use an adapter.
- Do not use an extension cord.
- Disconnect power before cleaning.
- Disconnect power before servicing.
- Use 2 or more people to move and install appliance.

SAVE THESE INSTRUCTIONS

IMPORTANT SAFEGUARDS



Before the appliance is used, it must be properly positioned and installed as described in this manual, so read the manual carefully. We strongly recommend that you have a professional install your new machine. The warranty may be affected or voided by an incorrect installation. To reduce the risk of fire, electrical shock or injury when using the appliance, follow basic precautions, including the following:

DANGER

- It is recommended that a separate circuit, serving only your appliance, be provided. Use receptacles that cannot be turned off by a switch or pull chain.
- Please ensure that the required voltage is being supplied at all times.
- The unit should be plugged into a grounded and properly-sized electrical outlet with appropriate over-current protection.
- Ensure unit is not resting on or against the electrical cord.
- Do not connect or disconnect the electric plug when your hands are wet.
- Never unplug the appliance by pulling on the power cord. Always grip the plug firmly and pull straight out from the outlet.
- Never clean appliance parts with flammable fluids. Do not store or use gasoline or other flammable vapors and liquids in the vicinity of this or any other appliance. The fumes can create a fire hazard or explosion.
- Before proceeding with cleaning and maintenance operations, make sure the power line of the unit is disconnected.
- Unplug the appliance or disconnect power before cleaning or servicing. Failure to do so can result in electrical shock or death.
- If the unit is not in use for a long period of time, best to unplug the unit from the outlet.
- After unplugging or a power outage to the unit, wait at least 10 minutes before plugging it back in. Failure to do so could cause damage to the compressor.
- Do not operate the appliance with a frayed or crimped power cord.
- Do not attempt to repair or replace any part of your appliance unless it is specifically recommended in this manual. A qualified technician should do all other servicing or repairs.

WARNING

- Use two or more people to move and install appliance. Failure to do so can result in back or other injury.
- This appliance must be properly installed and located in accordance with the Installation Instructions before it is used.
- Do not touch the cold surfaces in the appliance compartment when hands are damp or wet. Skin may stick to these extremely cold surfaces.
- Setting temperature controls to the ZERO (0) position does not remove power from the appliance, it must be turned off at the unit appliance circuit breaker or by unplugging it.
- To ensure proper ventilation for your appliance, choose a well-ventilated area with temperatures above 50°F (10°C) and below 86°F (30°C). If in an environment with a temperature between 86 and 104°F (30 to 40°C) use of a fan blowing into the utility compartment or similar auxiliary cooling of that area is required. This unit MUST be installed in an area protected from the elements, such as wind, rain, water spray or drips.
- The appliance should not be located next to ovens, grills or other sources of high heat.
- It is important for the appliance to be level for proper operation. You may need to make adjustments to level it.
- Remove the packing materials & be sure to discard them as the work area is policed. Clean the appliance before using.
- Do not use this apparatus for other than its intended purpose.
- Only trained, qualified personnel should attend to & monitor the appliance's performance and upkeep.
- Do not attempt to use the shelving as a ladder.

IMPORTANT SAFEGUARDS (cont.)

Electrical Connection

Do not, under any circumstances, cut or remove the third (ground) prong from the power cord. For personal safety, this appliance must be properly grounded. The power cord of this appliance is equipped with a 3-prong grounding plug that mates with a standard 3-prong grounding wall outlet to minimize the possibility of electric shock hazard from the appliance. Have the wall outlet and circuit checked by a qualified electrician to make sure the outlet is properly grounded. The appliance should always be plugged into its own individual electrical outlet which has a voltage rating that matches the rating label on the appliance. This provides the best performance and also prevents overloading house wiring circuits which could cause a fire hazard from overheated wires. Repair or replace immediately all power cords that have become frayed or otherwise damaged. Do not use a cord that has been crimped, shows cracks or has frayed insulation abrasion damage along its length or at either end. When moving the appliance, be careful not to damage the power cord.

Power Surges

Connecting the unit to the incorrect voltage or oversized circuit protection (i.e. a breaker rated for over 20 amps) is not covered by the appliance warranty. Neither is a damaged power cord, using unauthorized electrical components and/or modifying the units wiring.

It is recommended that the appliance circuit doesn't incorporate either a GFI breaker or outlet.

Any complications created by use of a GFI are not covered by the unit's warranty as they are prone to inadvertently tripping off to often.

Refrigerant Disposal

If you are throwing away your old appliance it may have a cooling system that uses "Ozone Depleting" chemicals. Make sure the refrigerant is removed for proper disposal by a qualified service technician.

Appliance Disposal

Follow and comply with all applicable codes and ordinances, cut the plug off the electrical power cord, remove the door(s) and discard the shelving. This prevents misuse of the unit after its been scrapped.

APPLIANCE INSTALLATION

WARNING

Excessive Weight Hazard

Use two or more persons to move and install appliances.
Failure to do so may result in back or other injury.

Remove Packaging Materials

IMPORTANT:

Do not remove any permanent instruction labels or the data label on your appliance.

- Remove tape and glue from your appliance before using.
- To remove any remaining tape or glue, rub the area briskly with your thumb. Tape or glue residue can also be easily removed by rubbing a small amount of liquid dish soap over the adhesive with your fingers. Wipe with warm water and dry with a soft cloth.
- Do not use sharp instruments, rubbing alcohol, flammable fluids, or abrasive cleaners to remove tape or glue. These products can damage the surface of your appliance.

NOTICE:

LOSS OR SPOILAGE OF PRODUCTS IN YOUR APPLIANCE IS NOT COVERED BY WARRANTY. IN ADDITION TO FOLLOWING RECOMMENDED INSTALLATION PROCEDURES AFTER ITS BEEN SET IN PLACE, DON'T RUN THE APPLIANCE 24 HOURS TO LET OIL IN THE REFRIGERANT LINE TO RE-EQUILIBRATE. (DON'T LOAD WITH PRODUCT UNTIL THE UNIT TEMPERATURE HAS REACHED ITS SET POINT.)

Location Requirements

- Appliances represented in this manual are intended for indoor use only.
- Be sure the location chosen has a floor strong enough to support the total weight of the cabinet and contents as a fully loaded unit can weigh as much as 1500 pounds.
- Reinforce the floor as necessary to provide for maximum loading.
- For the most efficient refrigeration, be sure to provide good air circulation inside and out.

Inside cabinet:

Do not pack the units so full that air cannot circulate. The refrigerated air is discharged at the top rear of the unit. It is important to allow for proper air flow from the top rear to the bottom of the unit. Obstructions to this air flow can cause evaporator coil freeze ups and loss of temperature or overflow of water from the evaporator drain pan. The shelves have a rear turn up on them to prevent this. However, bags and other items can still be located to the far rear of the cabinet. Air is brought into the evaporator coil with fans mounted to the front of the coil.

Outside cabinet:

Be sure that the unit has access to ample air. Avoid hot corners and locations near stoves and ovens.

It is recommended that the unit be installed no closer than 2" (51mm) from any wall, a max door swing clearance of 60.5 in. (1537mm) and with at least a 12" (305mm) of clear space above the unit. Adequate air flow ($\leq 86^{\circ}$ F) into the utility compartment is needed to deliver proper performance and extend the appliance life.

APPLIANCE INSTALLATION (cont.)

Installation Clearance

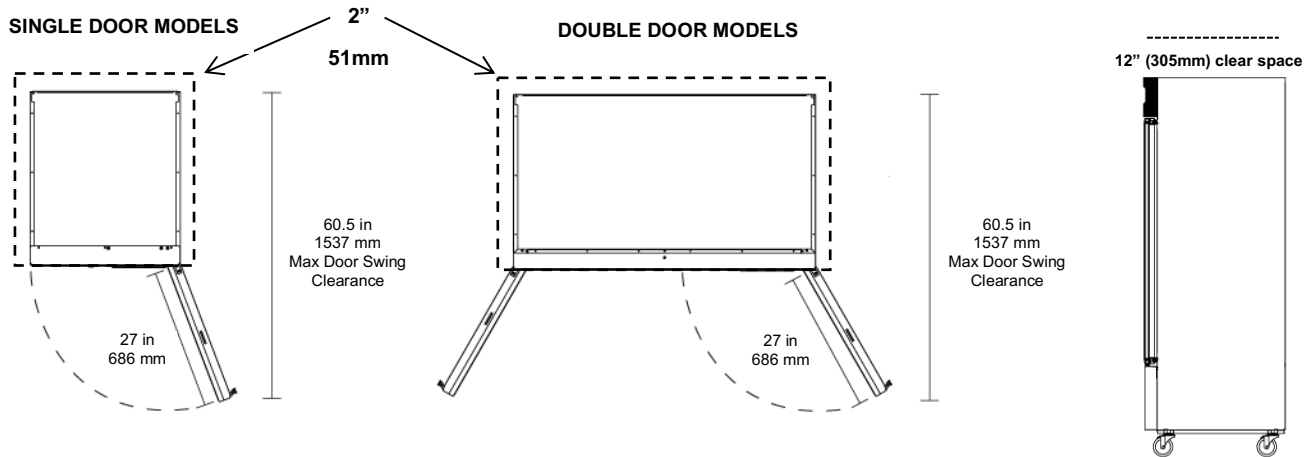

Leveling

Ensure the floor where the unit is to be located is level. (It is ok to slope down from front to rear by up to 1/4" – it mustn't slope from the rear to the front.)

Stabilizing

All models are supplied with casters for your convenience. It is very important, however, that the cabinet be installed in a stable condition with the front wheels locked while in use. Should it become necessary to lay the unit on its side or back for any reason, allow at least 24 hours before start-up to allow compressor oil to flow back into place. Failure to meet this requirement can cause compressor failure and unit damage which isn't covered by the appliance warranty.

Reversing The Door (Single Door Models Only)

Single door models can be converted from right-hand hinged to left-hand hinged and vice-versa by removing the door hinges from both the door and unit, reversing their locations and reattaching them, and re-hanging the door upside-down.

NOTICE:

Unit repairs will not be subject to standard unit warranties if due to improper installation procedures or utilizing an unqualified installer technician to commission the unit.

Electrical Connection

Refer to the amperage data on the Technical Information table, the serial tag, your local code or the National Electrical Code to be sure that unit is connected to the proper power source.



DANGER

The unit must be turned OFF and disconnected from the power source whenever performing service, maintenance functions or cleaning the refrigerated area. Failure to comply may result in Death or Severe Personnel Injury.

OPERATION

Refrigerated cycle

Freezers: The evaporator fans will run at any time when the evaporator coil temperature is below 54° F (12°C). Fans will also keep running when door is open but cycle off during a defrost period. The door switch will activate the lights when opened.

1. Every 8 hours, the unit will turn off and electric heater will turn on to defrost. The controller now displays the defrost symbol. When the coil temperature reaches 41°F (5°C) or after 30 minutes of defrost, the unit will turn on again.
2. Anti-condensation heaters on door frames work in conjunction with the compressor.
3. Recommended holding temperature range: -10° to 10°F (-23° to 12°C).
4. Comes factory set to -4°F (-20°C).

Power Switch:

The power switch is located on the front of the bottom panel. When the unit is on, the switch will glow green.

SOLID-STATE THERMOSTAT DESCRIPTIONS

1. FRONT PANEL COMMANDS.



SET: To display target set point; in programming mode it selects a parameter or confirm an operation.



To start a manual defrost.



In programming mode it browses the parameter codes or increases the displayed value.



In programming mode it browses the parameter codes or decreases the displayed value.

KEYS COMBINATION



To lock or unlock the keyboard.



To enter in programming mode.



To return to room temperature display.

1.1 Function of LEDS

LED	MODE	SIGNIFICANCE
	On	Compressor enabled
	Flashing	Anti short cycle delay enabled (AC parameter)
	On	Defrost in progress
	Flashing	Dripping in progress
	On	Fans output enabled
	Flashing	Fans delay after defrost
°C	On	Measurement unit
	Flashing	Programming mode
°F	On	Measurement unit
	Flashing	Programming mode

OPERATION (cont.)

2. MAIN FUNCTIONS

2.1 HOW TO SEE THE SET POINT

1. Push and immediately release the **SET** key, the set point will be showed;
2. Push and immediately release the **SET** key or wait about 5s to return to normal visualization.



2.2 HOW TO CHANGE THE SETPOINT

1. Push the SET key for more than 2 seconds to change the Set point value;
2. The value of the set point will be displayed and the “°C” or “°F” LED starts blinking;
3. To change the Set value push the \blacktriangle or \blacktriangledown arrows.
4. To memorize the new set point value push the SET key again or wait 10s.

2.3 HOW TO START A MANUAL DEFFROST

Push the **DEF**  key for more than 2 seconds and a manual defrost will start



2.4 TO LOCK THE KEYBOARD

1. Keep pressed for more than 3s the \blacktriangle and \blacktriangledown keys.
2. The “OF” message will be displayed and the keyboard will be locked. If a key is pressed more than 3s the “OF” message will be displayed.



2.5 TO UNLOCK THE KEYBOARD

Keep pressed together for more than 3s the \blacktriangle and \blacktriangledown keys till the “on” message will be displayed.

3. ALARM SIGNALLING

Mess.	Cause	Outputs
"P1"	Room probe failure	Compressor output according to "Cy" e "Cn"
"P2"	Evaporator probe failure	Defrost end is timed
"HA"	Maximum temperature alarm	Outputs unchanged
"LA"	Minimum temperature alarm	Outputs unchanged
"EA"	External alarm	Outputs unchanged
"CA"	Serious external alarm	All outputs OFF
"dA"	Door Open	Compressor and fans restarts

3.1. ALARM RECOVERY

Probe alarms **P1** and **P2** start some seconds after the fault in the related probe; they automatically stop some seconds after the probe restarts normal operation. Check connections before replacing the probe. Temperature alarms **HA** and **LA** automatically stop as soon as the temperature returns to normal values. Alarms **EA** and **CA** (with iF=bL) recover as soon as the digital input is disabled.

TIPS FOR PROPER OPERATION, CLEANING AND MAINTENANCE

1. The unit should be cleaned daily as well as being tested for the proper holding temperature by measuring the content temperature and comparing it to the temperature displayed on the controller. They should be within 3°F of each other.
2. When cleaning the exterior surface always use a soft cloth or microfiber towel. If a stiff bristle brush, scouring pad or scraper is used, the protective chromium oxide barrier will be penetrated allowing the appliance to show signs of rust.
3. When cleaning the interior or exterior of the appliance always use a mild detergent solution or warm soapy water. This won't harm the plastic or metallic substances and will remove most residual surface dust and grime. If a more aggressive cleaning is needed use a 3M Scotch Brite General Purpose Synthetic Fiber Green Scouring Pad and a solution of Dawn and warm water or a stainless steel cleaner/polishing product.
4. Ensure your gaskets are making a good compression seal and aren't torn or damaged as air entering the unit can increase the appliance's refrigeration system energy usage. In extreme cases, the temperature could fall out of range. When changing a gasket, it is recommended that a dab of gasket adhesive be applied every 10 to 12 inches to help hold the gasket in position. This escaping air may cause surface condensation.
5. Do not pack the unit so full that air cannot circulate. The refrigerated air is discharged at the bottom rear of the unit. It is important to allow for proper air flow from the top rear to the bottom of the unit.
6. Minimize the number of times the appliance door needs to be opened, as frequent access may preclude the unit's ability to maintain the proper temperature.
7. Use shelving with rear and side turn up rails to ensure proper air circulation is maintained as this is needed for effective, efficient temperature regulation.
8. Never use an infrared thermometer to monitor the unit's contents bulk temperature as they aren't accurate for this application. Use a NIST capable instrument with the right probe and calibrate the thermometer at least 3 times a year using an ice bath. Digital pocket thermometers may be off by as much as 1.8°F when measuring refrigerated products.
9. For best performance the ambient conditions should be less than 80°F with a relative humidity below 65%.
10. Ensure the automatic defrost cycle is set to keep the evaporator fan coil free of ice with proper air flow or the unit won't maintain the right temperature. The set point for a appliance should be between -13° and 14°F to preserve the shelf life and freshness of your stored products without needing to worry about a frozen evaporator.
11. Periodically inspect the displayed appliance temperature and measured steady state product temperature with a calibrated high-quality digital thermometer. The two readings should agree within 4° F and be below the recommended product holding temperature established by your operating procedures as well as the model food code.
12. The cooling fins are subject to clogging with grease, dust and other particulates even if an air filter is in place. The cooling fins should be cleaned using a commercial vacuum and if necessary, a degreaser at least 3 times a year. Do not use a wire or stiff bristle brush to avoid fin damage.
13. Any refrigeration system will generate condensate by cooling the air as it circulates through the appliance. At least twice a year, the drain line or condensate evaporator, tested to ensure the generated condensate is being adequately dealt with, and thoroughly cleaned/descaled so the condensate is always properly evacuated from the appliance.
14. The refrigeration system comes with a controller or thermostat to regulate the cold compartment temperature. New digital controllers have a differential setting that establishes when the refrigeration system cuts in and out around the selected set point. A 3° or 4°F differential is recommended for most applications to deliver tight temperature regulation without short cycling the compressor.
15. Only load the unit with pre-cooled product at temperature, warm product can result in undesired consequences.
16. Jerking on the door to reopen it immediately after its been closed (before the internal and external pressures are again equal) will damage the gasket necessitating its replacement and possibly result in higher holding temperatures for the appliance due to the continual ingress of warm air.

CLEANING AND MAINTENANCE



DANGER

The unit must be turned off and disconnected from the power source whenever performing service, maintenance functions or cleaning the refrigerated area. Failure to comply may result in death or severe personnel injury.

NOTE

Ongoing appropriate preventative & repair maintenance along with cleaning the unit will preserve its performance, deliver high quality fresher product and extend the appliance life.

Exterior and Interior Cleaning of Appliances

Clean using soap and warm water. If this isn't sufficient, try ammonia or a degreasing detergent (like Dawn) and water or a nonabrasive multi-surface liquid cleaner (like Formula 409). When cleaning the exterior, always rub with the "grain" of the stainless steel to avoid marring the finish.

- Do not use an abrasive cleaner because it will scratch the stainless steel and plastic and can damage the breaker strips and gaskets.

Cleaning the Condenser Coil

Regular cleaning is recommended every 90 days. In some instances, you may find that there is a large amount of debris and dust or grease accumulated prior to the 90 day time frame. In these cases the condenser coil should be cleaned every 30 days.

If the buildup on the coil consists of only light dust and debris, the condenser coil can be cleaned with a simple brush. Heavier dust build-up may require a vacuum or even compressed air to blow through the condenser coil.

If heavy grease is present, there are de-greasing agents available for refrigeration use and specifically for the condenser coils. The condenser coil may require cleaning with the de-greasing agent and then blown clear with compressed air or CO₂.

Failure to maintain a clean condenser coil can initially cause high temperatures and excessive run times. Continuous operation with dirty or clogged condenser coils can result in compressor failures. Neglecting the condenser coil cleaning procedures will void any warranties associated with the compressor or cost to replace the compressor.

- For efficient operation, keep the condenser surface free of dust, dirt, and lint.
- We recommend cleaning the condenser coil at least once per quarter more in a greasy/dust environment.
- Clean the condenser with a commercial condenser coil cleaner and a soft brush, available from any commercial refrigeration equipment retailer, or vacuuming the condenser with a shop vac or use CO₂.



CAUTION

Never use a high pressure water wash for this cleaning procedure as water can damage the electrical components located near or at the condenser coil.

In order to maintain proper refrigeration performance, the condenser fins must be clear of dust, dirt and grease regularly. It is recommended that this be done at least every three to 4 months. If conditions are such that the condenser is totally or significantly blocked in three months, the frequency of cleaning should be increased. Clean the condenser with a vacuum cleaner or stiff brush. If extremely dirty, a commercial-grade condenser cleaner may be required.

CLEANING AND MAINTENANCE (cont.)

Stainless Steel Care and Cleaning

To prevent rust or discoloration on stainless steel several important steps need to be taken. First, one must understand the properties of stainless steel. Stainless steel contains 70-80% iron which will rust. It also contains 12-30% chromium which forms an invisible passive film over the steel's surface which acts as a shield against corrosion. As long as the protective layer is intact, the metal is still stainless. If the film is broken or contaminated, outside elements can begin to breakdown the steel and begin to form rust or discoloration. Treating a surface showing rust with CitriSurf 2310 will help restore the protective chromium oxide layer as well as removing most of the surface rust when done as soon as any oxidation is noticed. At least every 6 weeks the stainless steel surfaces should be cleaned and treated with a cleaner/polish product like these stainless steel cleaner and polish offerings such as what Weiman, 3M 14 oz, Magic and Therapy products. Use of "hard water" with minerals like iron in it must be dealt with immediately (wipe dry) or the surface may tend to rust. Treating the water to soften it is suggested.



CAUTION

Proper cleaning of stainless steel requires soft cloths or plastic scouring pads, never use steel pads, wire brushes or scrapers! Use a 3M pad or a soft cloth – non-woven fabric works well.

Cleaning solutions need to be alkaline based or non-chloride based. Any cleaner containing chlorides will damage the protective film of the stainless steel. If cleaners containing chlorides are used, be sure to rinse and dry thoroughly (similar to the use of hard water).

Routine cleaning of stainless steel can be done with soap and water. Extreme stains or grease should be cleaned with a non-abrasive cleaner and plastic scrub pad. It is always good to rub with the grain of the steel. There are also stainless steel cleaners available which can restore and preserve the finish of the steel's protective layer.

Early signs of stainless steel breakdown can consist of small pits and cracks. If this has begun, clean thoroughly and start to apply stainless steel cleaners in attempt to restore the passivity of the steel.



CAUTION

Never use an acid based cleaning solution! Many food products have an acidic content which can deteriorate the finish. Be sure to clean the stainless steel surfaces of all food products.

Gasket Maintenance

Gaskets require regular cleaning to prevent mold and mildew build up and also to keep the elasticity of the gasket. Gasket cleaning can be done with the use of warm soapy water. Avoid full strength cleaning products on gaskets. Do not use sharp tools or knives to scrape or clean the gasket.

Gaskets can easily be replaced and don't require the use of tools or authorized service technicians. The gaskets are "Dart" style and can be pulled out of the groove in the door and replaced by pressing the new one back into place. Do not run the unit long after noticing the gasket is torn or not sealing – immediately schedule replacing it. Over time gaskets will wear, as such they and other wear parts are not covered by the appliance warranty.

Doors/Hinges

If the door is beginning to sag, tighten the screws that mount the hinge brackets to the frame of the unit. If the doors are loose or sagging, this can cause the hinge to pull out of the frame which may damage both doors and door hinges. (It may be necessary to insert some form of reinforcement if an old door & hinge set becomes loose so it can be tightened without stripping out of the body).

Drain Maintenance

Each unit has a drain located inside the unit which removes the condensation from the evaporator coil and evaporates it into an external condensate evaporator pan or feeds into a floor drain sump. The drain can become loose or disconnected. If you notice excessive water accumulation on the inside of the unit, be sure the drain tube is connected from the evaporator housing to the condensate evaporator drain pan.

If water starts to collect underneath the unit, check the condensate evaporator drain tube to be sure it is still located inside the drain pan. Also confirm the evaporator pan (where the condensate cannot feed into a floor drain) is keeping up with the discharge water, if not a larger electric condensate pan is needed. Excessive moisture or frequent accessing of the appliance content in a fairly humid ambient creates the need for a larger and more powerful condensate evaporator which isn't covered by the appliance warranty.

If your floor is not level, this can also cause drain problems. Be sure all drain lines are free of obstructions because this may cause water to back up and overflow the drain pans.

TROUBLESHOOTING GUIDE

BEFORE CALLING FOR SERVICE

If the unit appears to be malfunctioning, read through the OPERATION section of this manual first. If the problem persists, see Troubleshooting chart below. The problem may be something very simple that can be solved without a service call. Always see if this chart describes the problem, identifies the cause and offers a remedy.

TROUBLESHOOTING CHART

Fault	Probable Cause	Action
The evaporator is iced over	The unit is exposed to excessive moisture or the auto defrost cycle is set incorrectly	Run the manual defrost cycle or unplug the unit and open the door
There is a loud noise	The floor is too weak or the unit is not level	Check the installation confirming the unit is level and adjust the tray position
	The back of the unit is too close to the wall	
	The tray is not in the correct position	
	The fan blade may be obstructed or unbalanced	Clear the fan blade obstruction or replace the fan
Compressor is Not Running	Fuse blown or circuit breaker tripped	Replace fuse or reset circuit breaker. If replacement of fuse or reset of circuit breaker doesn't correct the problem contact a qualified service technician.
	Power cord unplugged	Plug in power cord and check that the relevant breaker isn't tripped
	Thermostat set too high	Set thermostat to lower temperature
	A ground fault protector has tripped	Reset or eliminate the GFI breaker or receptacle
Cabinet Temperature is too Warm	Thermostat is set too high	Set thermostat to lower temperature.
	Airflow is blocked	Re-arrange products to allow for proper air flow. Make sure there is at least four inches of clearance from the fan
	Low refrigerant levels	Contact a qualified service technician to check refrigerant levels
	Door is slightly ajar	Make sure door is completely closed.

TROUBLESHOOTING (cont.)

Fault	Probable Cause	Action
Water is pooling up on the floor near the appliance	The condensate pan isn't keeping up and is overflowing	Check the hot gas line temperature
		Add an additional powered condensate evaporator pan to accommodate the overflow
	If connected to a floor drain the setup has become misaligned and/or the drain line may be clogged	Reposition the drain line so it flows into the floor drain
Clear the drain line		
Interior Light is Not Working	Poor switch connection	Turn off light switch and turn it back on.
	Bulb is not connected	Make sure the bulb is correctly inserted in the socket.
	Bulb has burned out	Replace the bulb. If replacement of bulb doesn't correct the problem contact a qualified service technician.
Condensation is Collecting on the cabinet and/or floor	Gasket is not sealing properly	Clean, repair, or replace the gasket as necessary
	High humidity / moisture in the air is causing dew drops	Wipe with a dry cloth
Gasket is tearing or being pulled out of it's slot	Opening door immediately/toon soon after it has been closed	Don't jerk on the door and allow enough time for the internal pressures to equalize.
The door does not close tightly	The door is bent	A replacement door may be necessary
	The door gasket has come out	Reposition or replace the gasket
	The unit is not level	Level the unit again
	Hinge has loosened	Tighten the door hinge and ensure it is secure

SERVICE AND TROUBLESHOOTING TIPS

1. The compressor comes with a 5 year limited warranty (1 year parts and labor and the subsequent 4 years part only). Properly assess the root cause of the problem, as issues that can cause similar symptoms such as weak refrigerant charge (leaks), condensing unit fan not performing properly, temperature controller failure, faulty starting or running components and filter drier needing replacement are not covered by the warranty. Service technician in years 2-5 must affirm the failure is the compressor and not the listed reasons.
2. The appliance is outfitted with Schrader access ports to make servicing easier enabling use of a pressure gauge connected to either the high or low side as well as facilitating applying a vacuum and recharging the refrigeration system.
3. A dirty or clogged condenser is not covered by the warranty.
4. After 30 days in service, gaskets and the door(s) sealing improperly are not covered by our warranty.
5. If the set point or auto defrost cycle program are misadjusted that condition is not covered by our warranty
6. A perimeter door heater can be replaced by removing the cover plate and replacing the heat cord element.

DIMENSIONS AND TECHNICAL INFORMATION

SINGLE DOOR MODELS

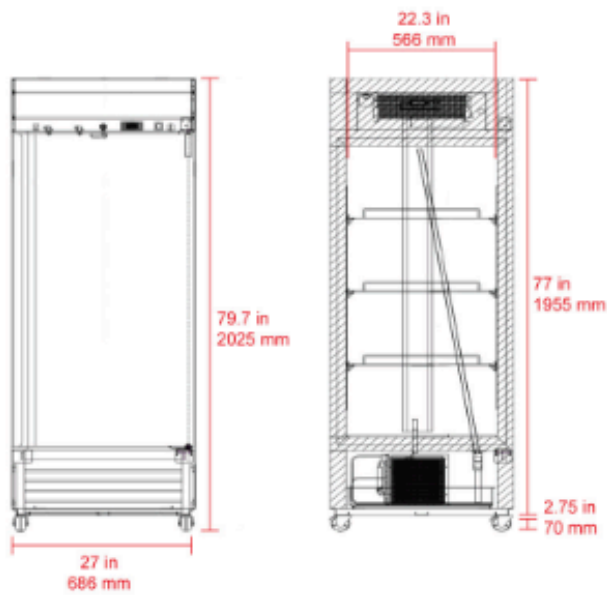

SIDE VIEW (ALL MODELS)

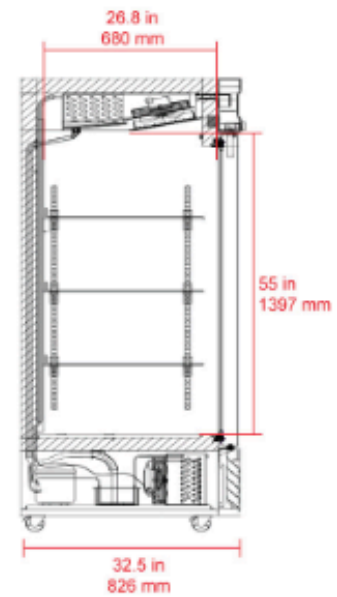

DOUBLE DOOR MODELS

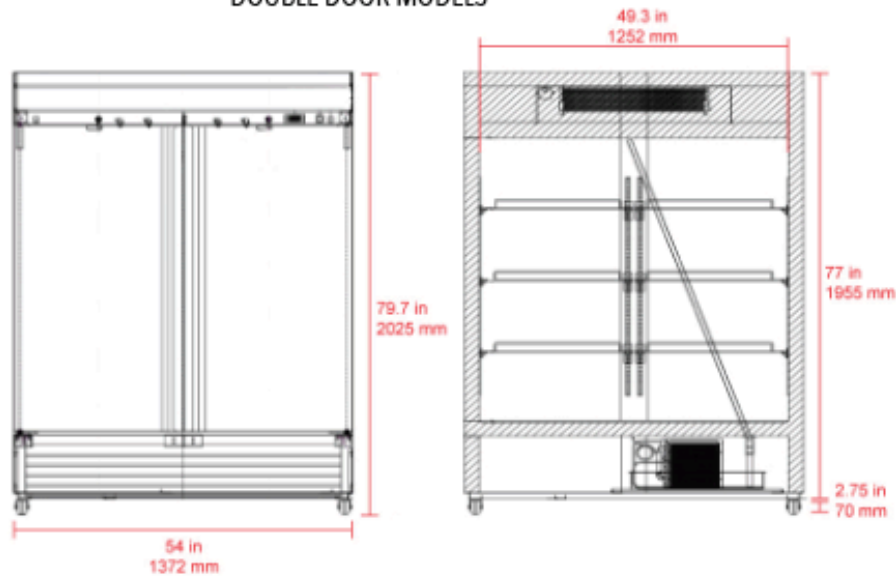

Model	Dim (W"xD"xH")	Actual/Nominal Capacity	Temp	HP Rating	Shipping / Net Weight	Cooling Capacity	Average Amp Draw	Peak Amp Draw
68K-765HC	27 x 32.5 x 79.7 686 x 825 x 2025 mm	19.3 / 23 Cu Ft 547 / 651 L	-10° to 10° F -23° to -12° C	5/8	310 / 285 lb	2600 BTU/hr	6 A	12 A
68K-774HC	54.1 x 32.5 x 79.7 1372 x 825 x 2025 mm	42.9 / 49 Cu Ft 1215 / 1388 L	-10° to 10° F -23° to -12° C	1	460 / 425 lb	3750 BTU/hr	9 A	14 A
69K-889HC	27 x 32.5 x 79.7 686 x 825 x 2025 mm	19.3 / 23 Cu Ft 547 / 651 L	-10° to 10° F -23° to -12° C	5/8	310 / 285 lb	2600 BTU/hr	6 A	12 A
69K-890HC	54.1 x 32.5 x 79.7 1372 x 825 x 2025 mm	42.9 / 49 Cu Ft 1215 / 1388 L	-10° to 10° F -23° to -12° C	1	460 / 425 lb	3750 BTU/hr	9 A	14 A

COMPONENT INFORMATION

SINGLE DOOR MODELS

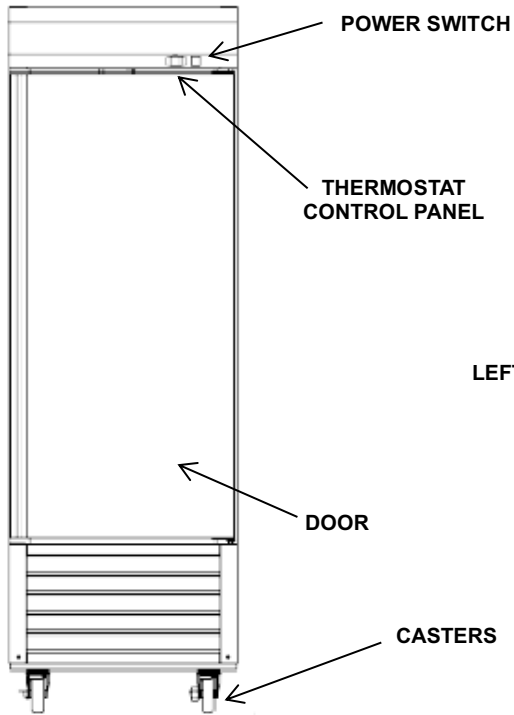

DOUBLE DOOR MODELS

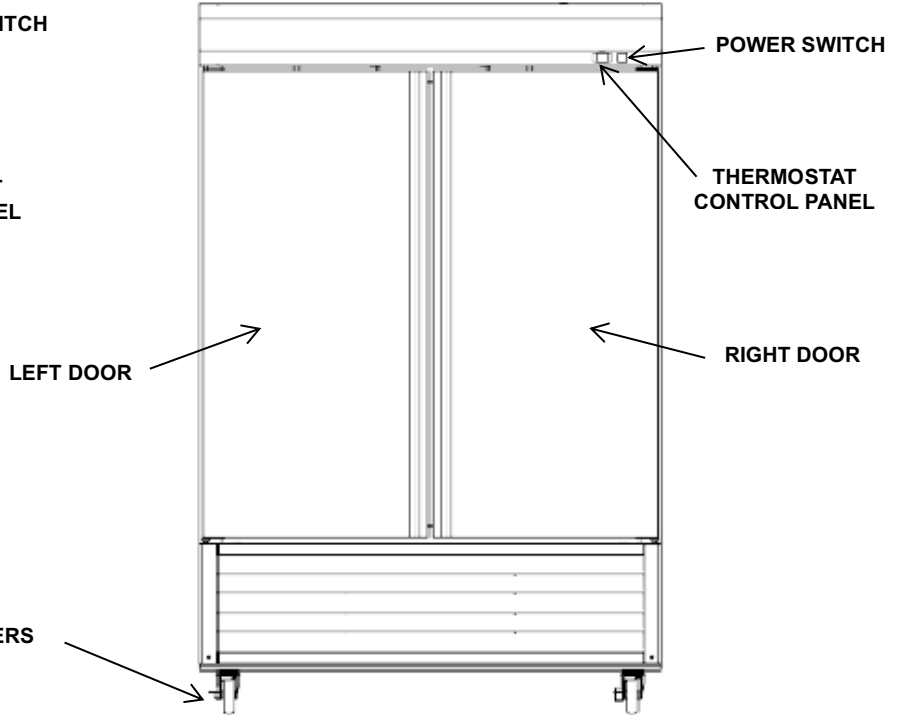

REFRIGERATION DIAGRAM

R290A REFRIGERANT

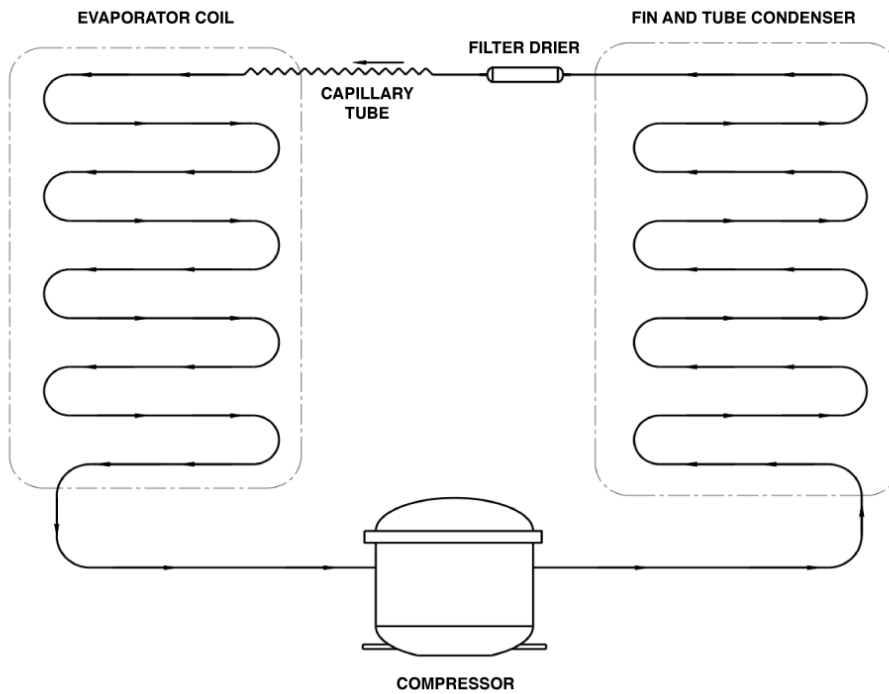

WIRING DIAGRAMS

SINGLE DOOR MODELS :

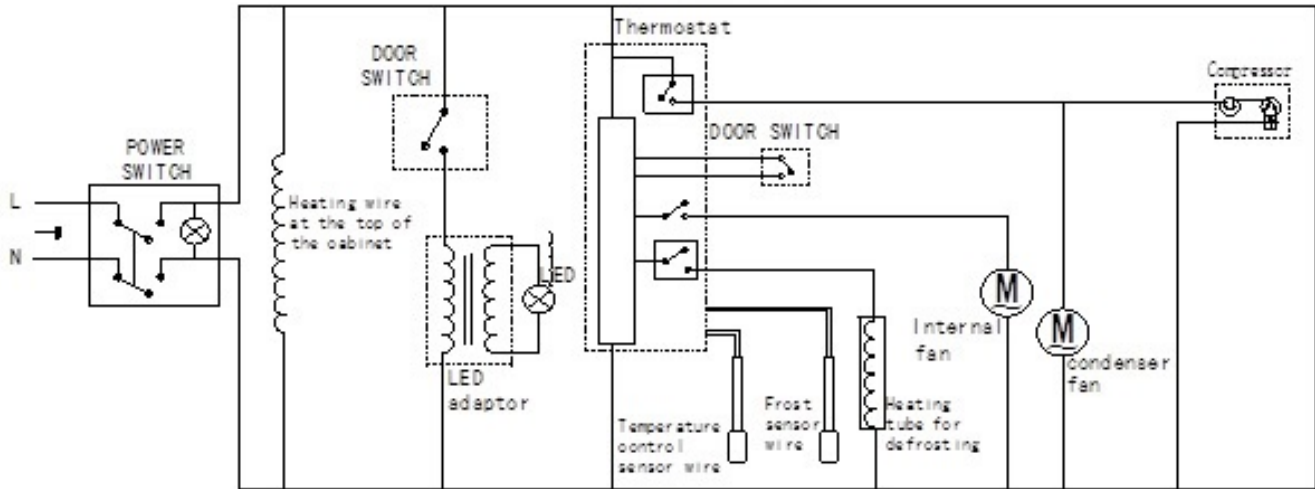

DOUBLE DOOR MODELS :

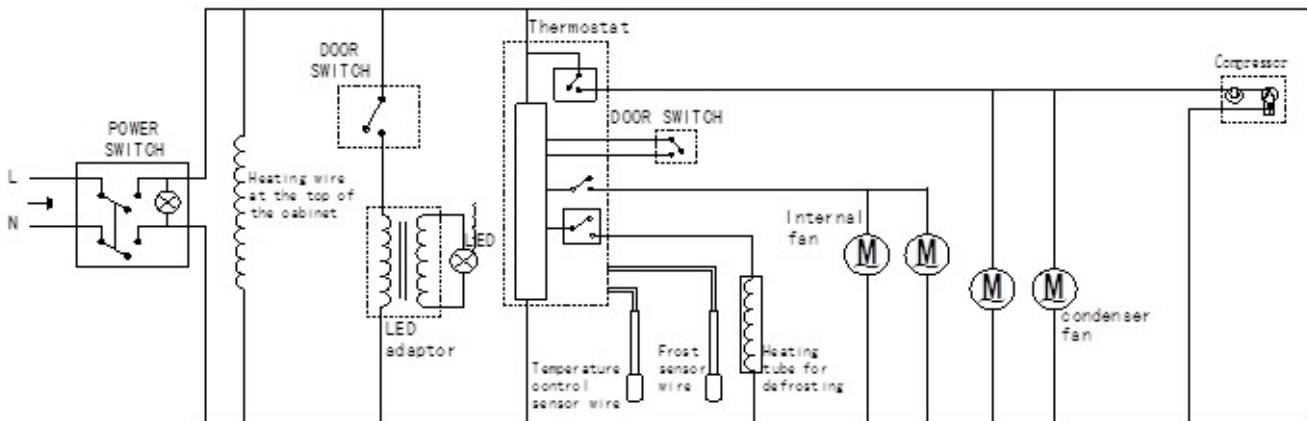

PARTS

SINGLE DOOR MODELS

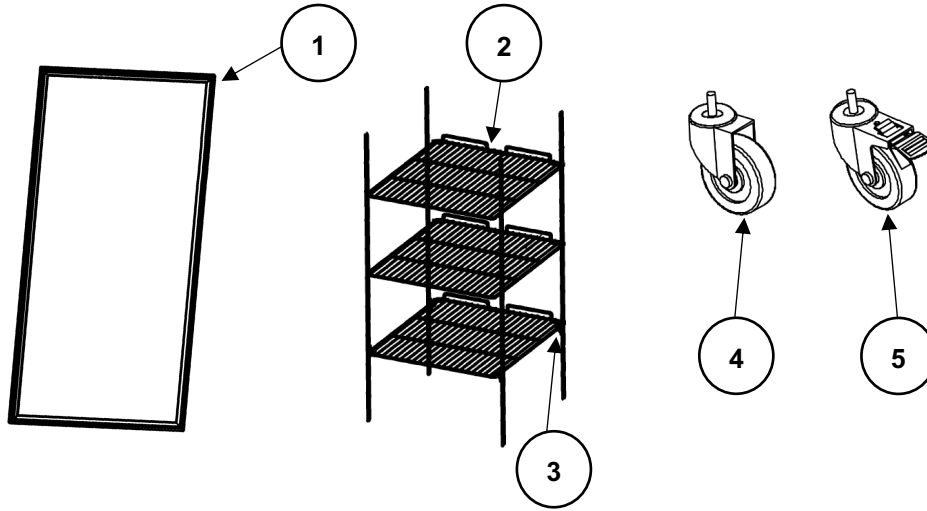

Item #	Part Number	Descriptions	Qty / Unit
1	SKA-2-110-0047-0	Gasket (door)	1
2	SKA-2-120-0016-0	Shelf	3
3	SKC-2-110-0625-0	Shelf Clip	12
4	SKA-2-140-0002-0	Caster	2
5	SKA-2-140-0001-0	Caster with brake	2

DOUBLE DOOR MODELS

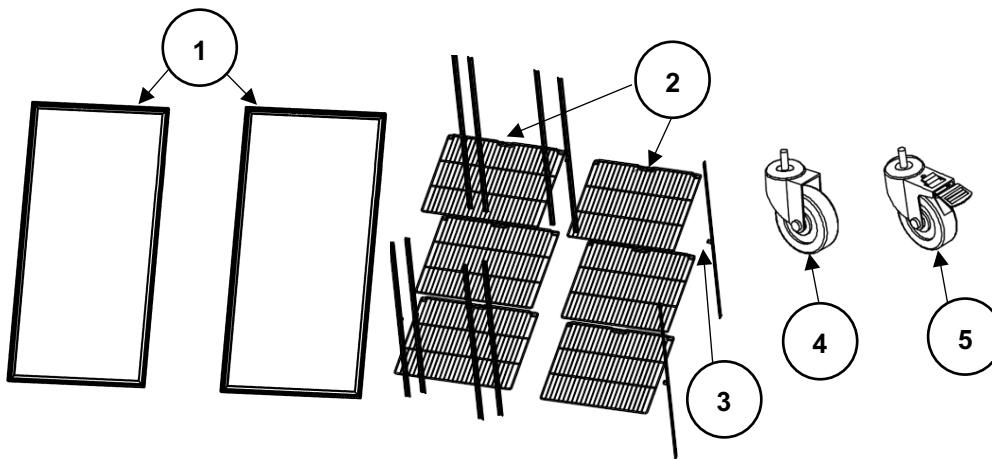

Item #	Part Number	Descriptions	Qty / Unit
1	SKA-2-110-0047-0	Gasket (door)	2
2	SKA-2-120-0015-0	Shelf	6
3	SKC-2-110-0625-0	Shelf Clip	24
4	SKA-2-140-0002-0	Caster	2
5	SKA-2-140-0001-0	Caster with brake	2

Reference Material:

Contact information for your local service providers to expedite technical support and repair if it is necessary in the future.

PRIMARY CONTACT	SECONDARY CONTACT
Firm Name:	Firm Name:
Email:	Email:
Phone No.:	Phone No.:
Street Address:	Street Address:
NOTES:	NOTES:



7750 Georgetown Road, Indianapolis, IN 46268 USA
Phone: (317) 634-2550