

# CU50 Service Parts

This is the illustrated parts list for the CU50 Cube Ice Machines

When ordering a service part, always refer to the complete model number of the equipment being repaired to be sure of obtaining the correct part. Many times there are slight differences between models, and having the complete model number will aide in selecting the correct part.

The cabinet changed in November 2014 to include a service panel.

## Table of Contents

Door Components . . . . .	Page 2
Cabinet . . . . .	Page 3
Reservoir and Spray Pump . . . . .	Page 4
Refrigeration . . . . .	Page 5
Under Bin Parts . . . . .	Page 6
Control System . . . . .	Page 7
Schematic Diagram . . . . .	Page 8
Wiring Diagram . . . . .	Page 9

# CU50 Service Parts

## Door Components

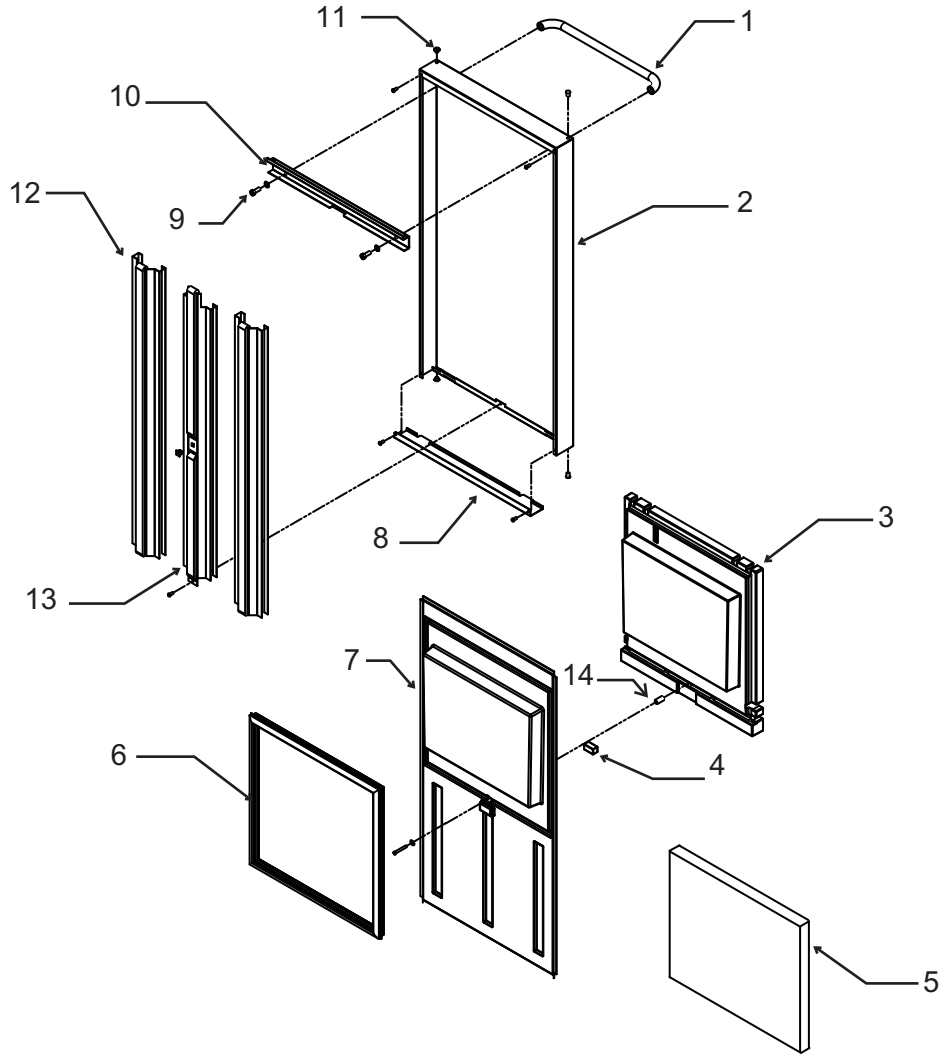

Item Number	Part Number	Description
1	02-3847-01	Handle, door
2	A39678-001	Door panel
3	02-4445-01	Insulation, upper
4	11-0587-01	Magnet, door
5	02-4570-01	Insulation, lower
6	13-0949-03	Door gasket
7	02-4569-01	Liner, door
8	A39676-001	Door bottom
9	03-3814-02	Screw, handle
10	A39675-001	Bracket, door handle
11	03-3927-01	Bushing, door hinge, same on bottom
12	A39677-001	Door support
13	A39677-002	Door support, center
14	03-3926-01	Spacer
15	A39860-001	Complete door, assembled. Includes all above parts

# CU50 Service Parts

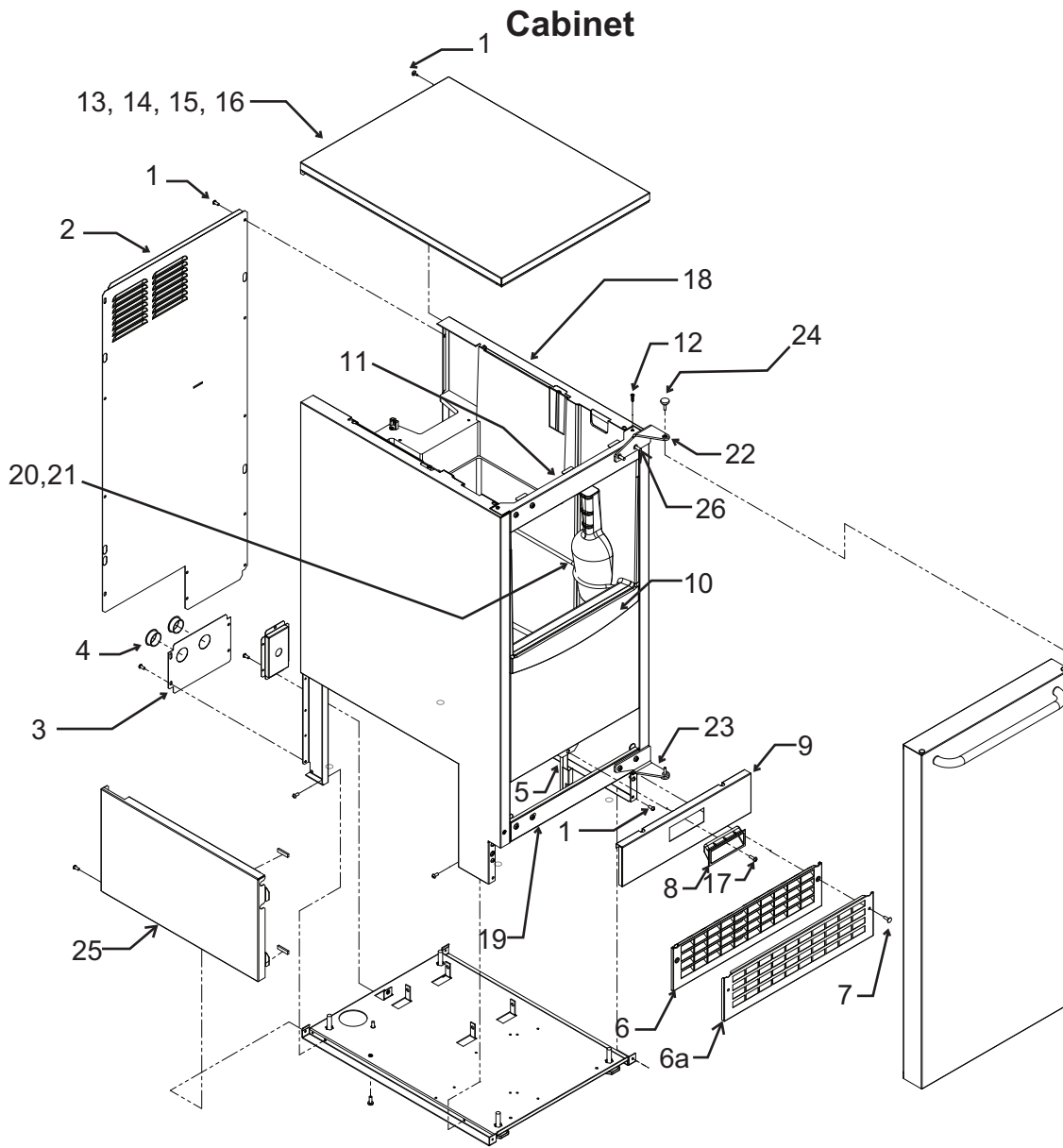

Item Number	Part Number	Description	Item Number	Part Number	Description
1	03-1531-01	Screw	12	03-3836-03	Screw
2	A39363-001	Back panel	13	02-4438-01	Gasket - for edges
3	A39389-001	Utility routing bracket	14	02-4438-02	Gasket strip - across
4	12-1213-11	Snap bushing	15	02-4426-01	Insulation pad
5	A39392-001	Srv panel mntg bracket	16	A39362-003	Top panel, SS
6	02-4390-01	Kickplate	17	03-1403-86	Screw
6a	A39469-001	SS kickplate	18	A39618-002	SS cabinet & bin
7	03-1403-86	Screw	19	A39700-001	Bottom hinge panel, SS
8	02-4441-01	Panel handle	20	A39379-001	Bin stat bracket/scoop hldr
9	A39381-003	Service panel, SS	21	02-4391-03	Scoop
10	02-4392-01	Bin edging	22	02-4568-02	Hinge
11	A39699-001	Top hinge panel, SS	23	02-4568-01	Hinge
			24	03-3834-01	Pin, hinge
			25	A39615-001	Service panel
			26	03-8318-01	Hinge mounting screw

# CU50 Service Parts

## Reservoir and Spray Pump

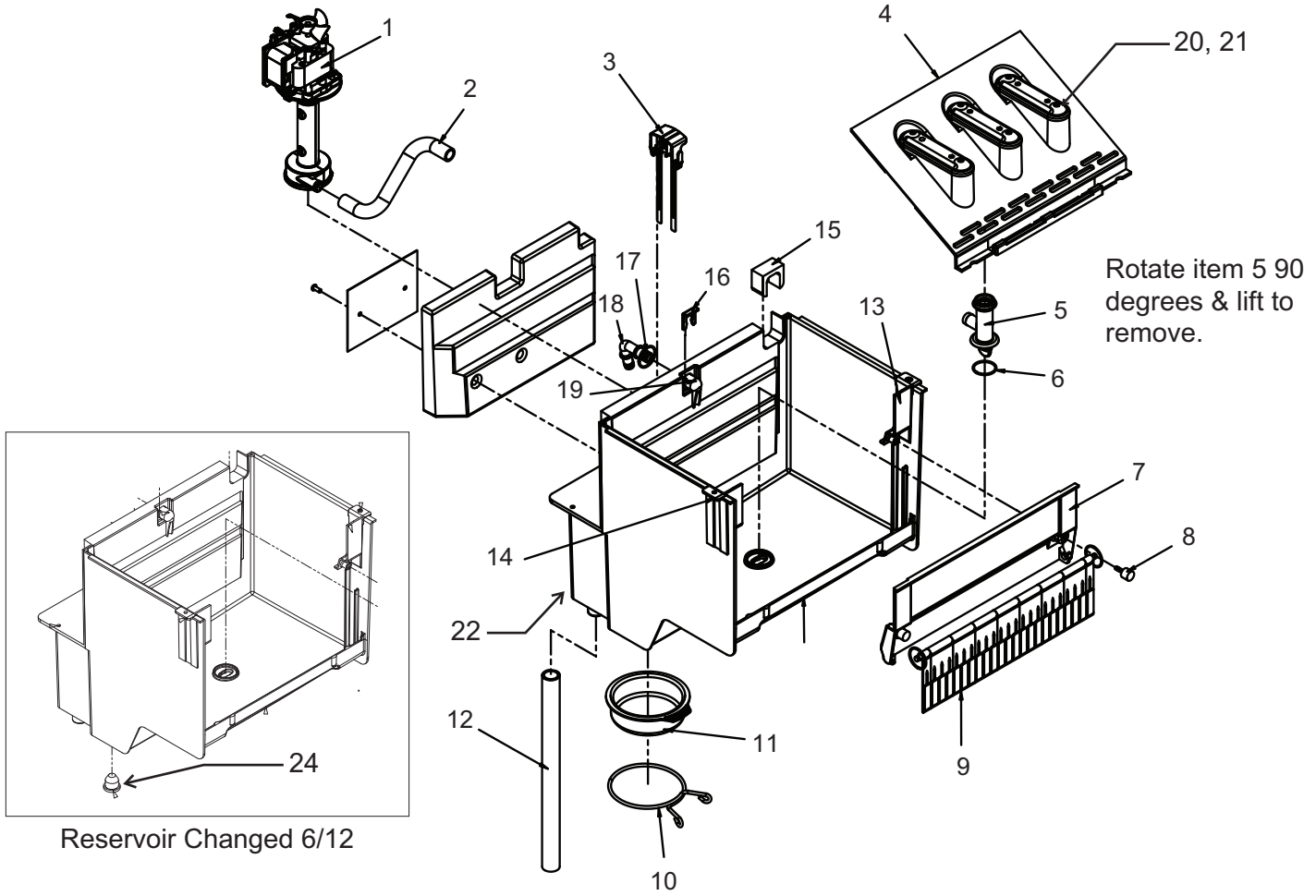

Reservoir Changed 6/12

Item Number	Part Number	Description
1	12-2986-21	Water pump
2	02-4379-01	Pump discharge hose
3	A39030-023	Water probe
4	02-4371-03	Spray platform
5	02-4368-01	Water Tee
6	13-0617-11	O-ring
7	02-4365-01	Front bracket
8	03-3892-01	Thumb screw
9	A39357-001	Curtain
10	02-4383-01	Clamp
11	02-4369-01	Drain cap
12	02-4428-01	Drain tube
13	02-4375-02	Evap bracket, left
14	02-4375-01	Evap bracket, right
15	02-4475-02	Grommet
16	02-4381-03	Clip
17	13-0617-04	O-ring
18	02-4381-01	Barbed fitting
19	02-4381-02	Spout
20	02-4373-01	O-ring
21	02-4370-21	Spray nozzle, kit. Set of 3 nozzles, o-rings, screws and nuts.
22	02-4427-01	Reservoir
Item 23 not shown, added in 2013		
23	02-4726-01	Evaporator cover
24	13-0840-01	Drain plug

# CU50 Service Parts

## Refrigeration

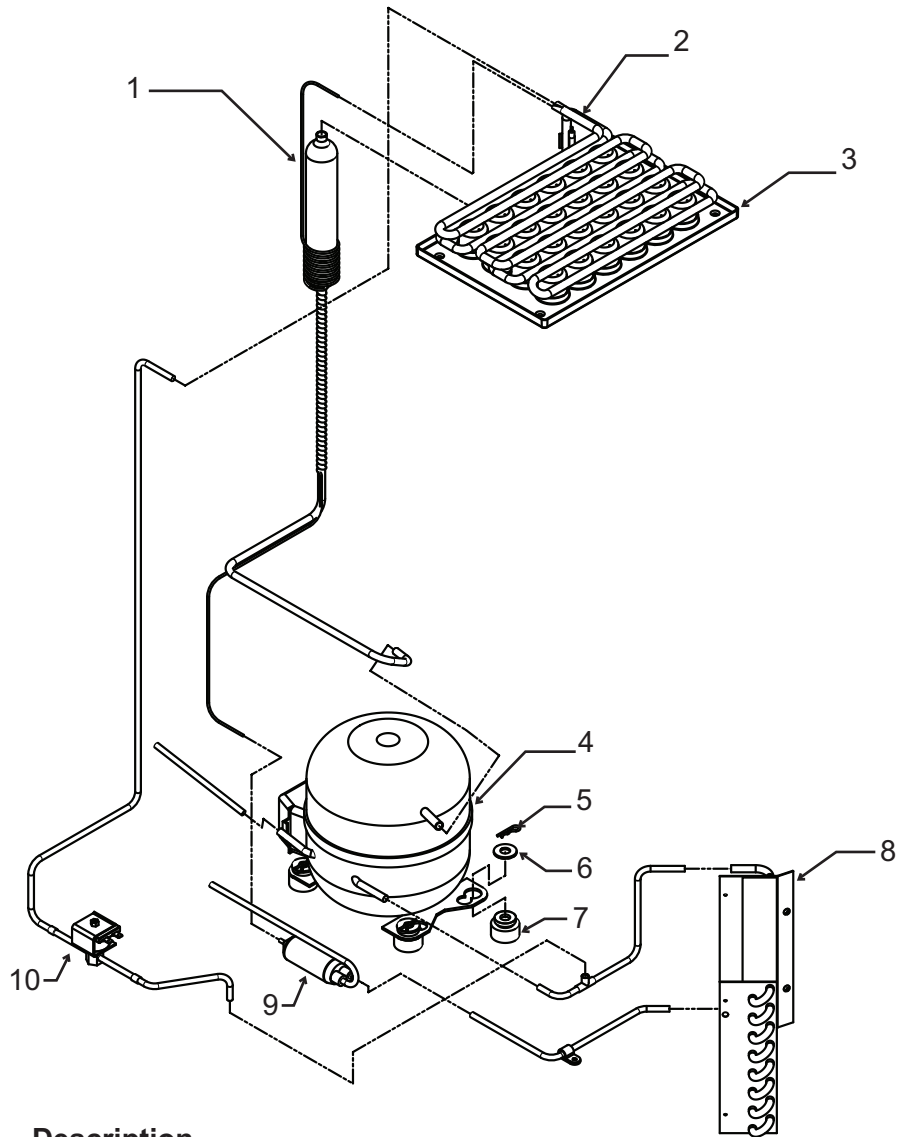

Item Number	Part Number	Description
1	A39384-001	Suction line accumulator assy
2	11-0577-01	Thermistor
3	02-4376-03	Evaporator
4	18-8939-21	Compressor
Compressor includes overload, relay and drier		
4a	18-8939-51	Overload
4b	18-8939-52	Relay
5	03-3821-01	Clip
6	03-1407-08	Washer
7	18-4700-28	Grommet
8	18-8940-01	Condenser
9	02-4416-01	Drier
10	11-0562-21	Hot gas valve
10a	11-0562-22	HGV coil

# CU50 Service Parts

## Under Bin Parts

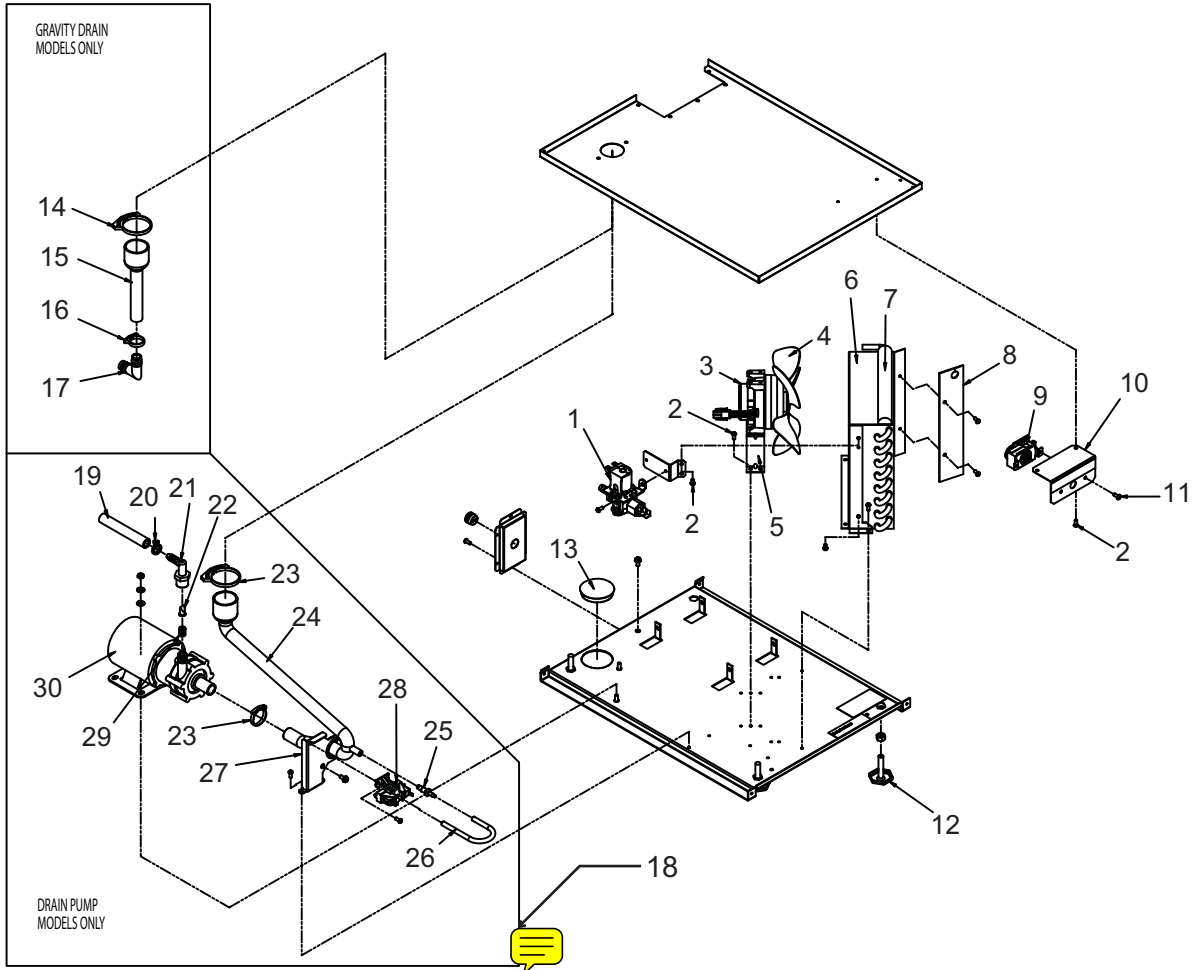

Item Number	Part Number	Description
1	12-2990-01	Inlet water sol valve
2	03-1531-01	Screw
3	12-3024-01	Fan motor
4	02-4197-01	Fan blade
5	A39556-001	Fan motor bracket
6	A39460-001	Fan shroud
7	13-0909-01	Gasket, order 1 & cut to fit
8	02-4450-01	Air baffle
9	11-0617-21	Thermostat
10	A39379-001	Thermostat bracket
11	03-1403-16	Screw
12	03-1608-01	Leg leveler
12a	02-4415-01	Leg cap
13	02-1875-18	Hole plug
14	02-2814-13	Hose clamp
15	02-4412-01	Drain hose
16	02-2814-08	Hose clamp
17	16-0671-01	Elbow
18	A39462-021	Pump kit
19	A37334-001	Discharge hose
20	02-0534-02	Hose clamp
21	02-3522-01	Elbow
22	02-3374-01	Check valve
23	02-2814-13	Hose clamp
24	02-4413-01	Drain tube
25	02-3406-01	Barbed connector
26	05-0591-01	Switch hose
27	A39370-001	Switch bracket
28	11-0504-01	Pressure switch
29	03-3904-01	Spring
30	12-2503-21	Pump & motor only

# CU50 Service Parts

## Control System

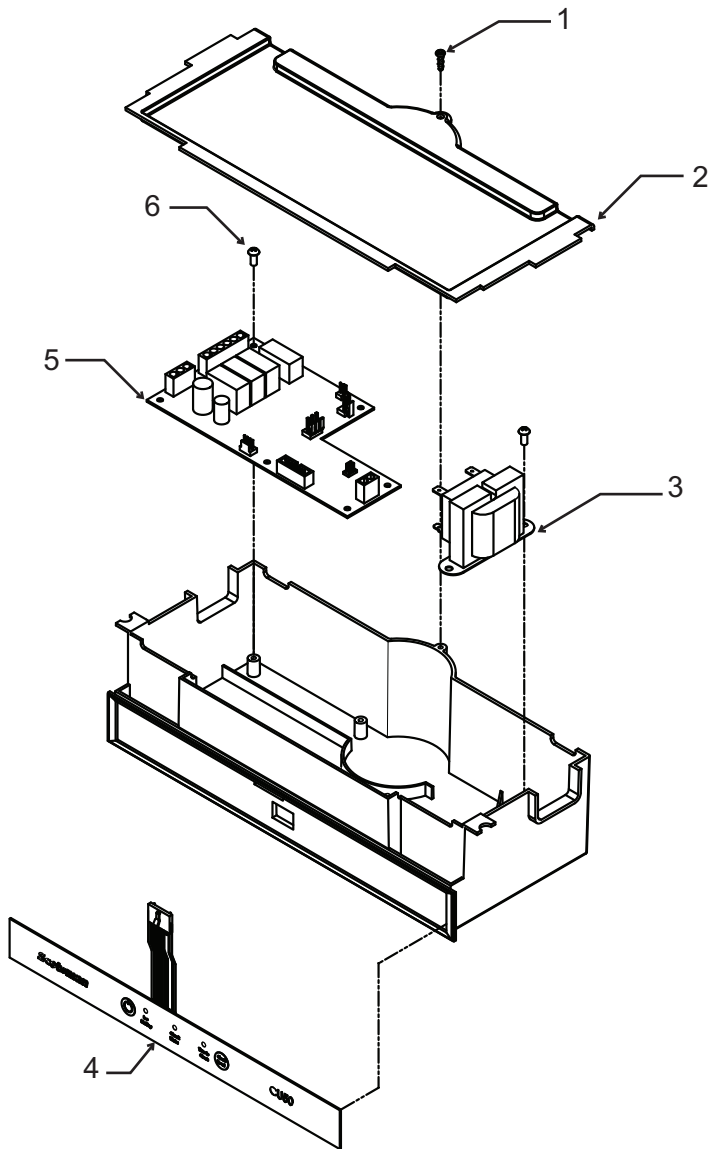

Item Number	Part Number	Description
1	03-3836-03	Screw
2	02-4386-01	Cover
3	12-2924-01	Transformer
4	11-0588-01	Switch panel
5	11-0573-25	Controller
6	03-1531-01	Screw

### Not Shown:

NS1	12-3003-01	Bin stat harness
NS2	12-3000-02	Hi voltage harness, lower
NS3	12-3000-01	Hi voltage harness, upper

**Note: If replacing the lower harness, always replace the upper one too.**

NS4	12-2992-01	Water sensor harness
-----	------------	----------------------

# CU50 Service Parts

## Schematic Diagram

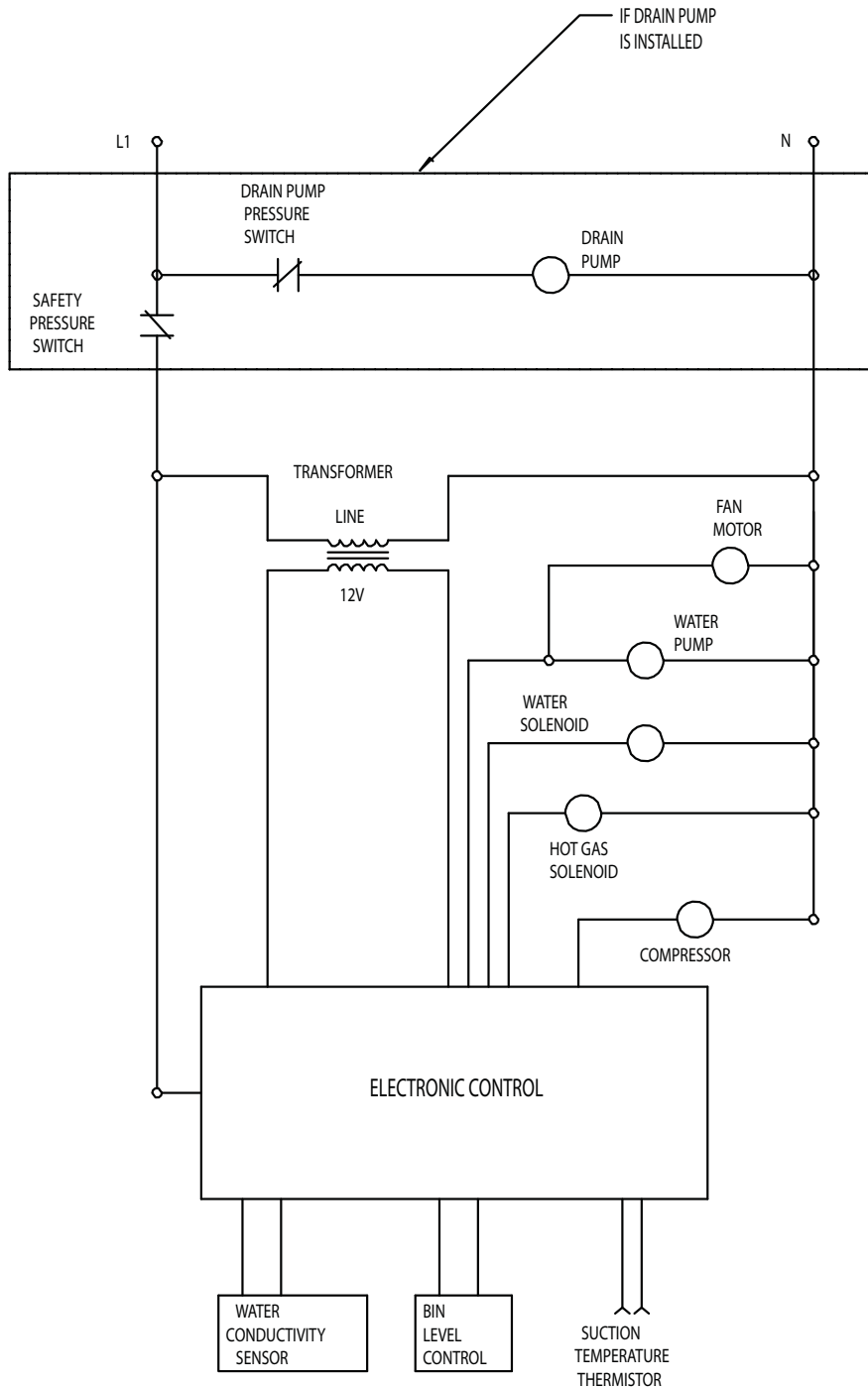

SWITCHES ON THIS UNIT  
SHOWN IN FREEZE CYCLE  
WITH DRAIN PUMP IN OPERATION  
AND BIN DOOR CLOSED



# CU50 Service Parts

## Wiring Diagram

