



ITEM #: \_\_\_\_\_ QTY: \_\_\_\_\_  
 MODEL #: \_\_\_\_\_  
 PROJECT NAME: \_\_\_\_\_

062119

3601 S. Banker St. Effingham, IL 62401 • P.O. BOX 609 • Ph: (888) 431-2667 • Fax: (800) 433-2667

## "MCS3" 3 COMPARTMENT MOBILE SINK



### FEATURES:

- 16GA TYPE 300 STAINLESS STEEL TOP WITH #4 POLISH, SATIN FINISH
- 18GA STAINLESS STEEL PANELS
- 18GA STAINLESS STEEL HINGED DOORS WITH MAGNETIC CATCHES
- MARINE EDGE ON FRONT
- 16GA 6" REAR RISERS AND SIDE SPLASHES
- 3 WELD IN SINK BOWLS 10" X 14" X 5"
- SIDE MOUNT HAND SINK WITH WELD IN SINK BOWL 10" X 14" X 5"
- TWO HEAVY DUTY 10" SWING SPOUT DECK MOUNT FAUCETS, 4" O.C.
- HEAVY DUTY 5" LOCKING CASTERS
- 2 WATER SUPPLY OPTIONS, 20 GALLON CLEAN TANK OR CONSTANT SUPPLY CITY WATER
- SHURFLO FRESH WATER PUMP
- ARISTON GL2.5 WATER HEATER
- 20 GALLON CLEAN WATER TANK
- 30 GALLON WASTE WATER TANK
- SOAP AND TOWEL DISPENSER
- GFI WITH 6' CORD
- ALL COMPONENTS ARE UL LISTED

### CONSTRUCTION:

- TIG WELDED, EXPOSED WELDS ARE POLISHED TO MATCH ADJACENT SURFACE.

### MATERIAL:

- TOP: 16GA TYPE 300 STAINLESS STEEL TOP WITH #4 POLISH, SATIN FINISH
- PANELS: 18 GAUGE STAINLESS STEEL
- DOOR: 18GA STAINLESS STEEL WITH MAGNETIC CATCHES



### **3 COMPARTMENT MOBILE SINK**

MODEL	QTY
MCS3-1014-HS	

## DETAILED SPECIFICATIONS

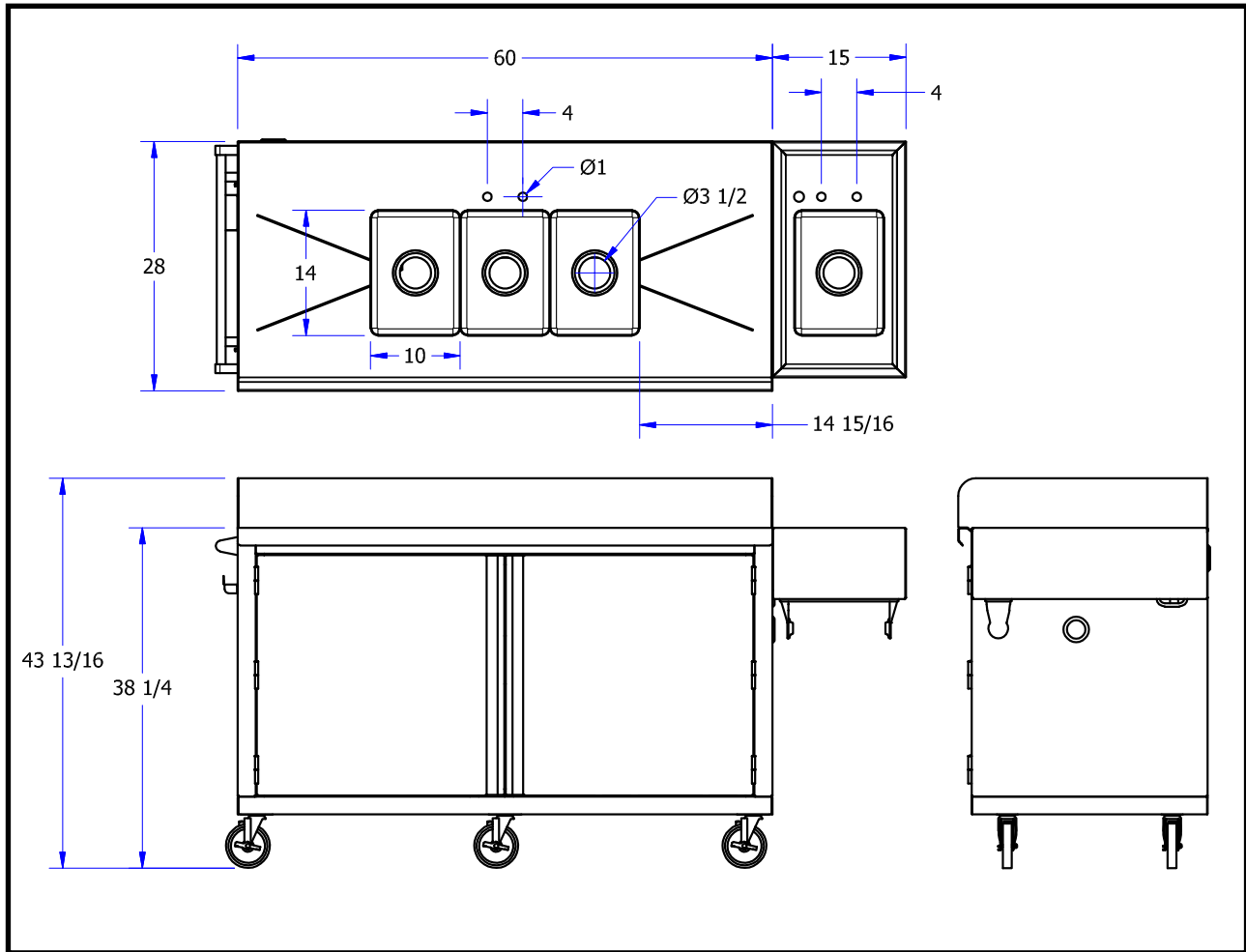

### 3 COMPARTMENT MOBILE SINK

MODEL	OVERALL SIZE (LxWxH)	SINK SIZE (LxWxH)	WT. (LBS)
MCS3-1014-HS	75"X28"X43-13/16"	10"X14"X5"	359

SOME UNITS SHIP UNASSEMBLED FOR REDUCED SHIPPING COST. ALL DIMENSIONS ARE TYPICAL. TOLERANCE +/- .500"  
 John Boos & Co. is constantly engaged in a program of improving products and therefore reserves the right to change specifications without prior notice.



*Boos*  
lock

AQ AutoQuotes

3601 S. Banker St. • Effingham, IL 62401 • PO BOX 609 • quotes@johnboos.com

www.johnboos.com

062119

645