



# STAR-MAX<sup>®</sup> GAS FRYERS

## Models 615FD & 630FD

### Features/Benefits:

- ★ Star-Max underfired gas countertop fryers are perfect for a variety of menu items.
- ★ Model 615FD features a heavy-duty 15 pound capacity nickel plated steel kettle with convenient front access drain valve.
- ★ Model 630FD features a heavy-duty 30 pound capacity nickel plated steel kettle with convenient front access drain valve.
- ★ Model 615FD features 30,000 BTU's and the model 630FD features 70,000 BTU's (65,000 BTU's for LP use) providing fast recovery and maximum performance.
- ★ High performance in-shot burner design with copper plated kettle fins for even heat distribution and optimal heat transfer.
- ★ Snap action thermostat ranges from 200°F to 375°F and provides quick response to temperature change.
- ★ Automatic pilot light for quick and easy ignition.
- ★ Two nickel plated steel mesh side hanging baskets are standard providing continuous flow of product during peak periods.  
Model 615FD basket - 4"W x 4-3/4"D x 11"L  
Model 630FD basket - 8-3/4"W x 5-1/4"D x 10"L.
- ★ Units are compact requiring only 12" or 24" of counterspace.
- ★ Heavy-duty 4" adjustable legs to match the height of other Star-Max equipment in your line
- ★ An optional full basket (8-3/4"W x 5-1/4"D x 10"L) is available for the model 615FD.



Model 615FD



Model 630FD

### Applications:

Star-Max gas countertop fryers are a perfect addition to your foodservice operation. Breakfast, lunch or dinner, Star's coated top fryer is the perfect addition to your restaurant, snack bar or any food service establishment requiring a counter model fryer. Easy to operate and clean, Star-Max fryer delivers maximum performance year after year.

### Quality Construction:

Fryers are constructed of heavy gauge polished stainless steel. The nickel plated kettle features a copper plated bottom and 1/4 turn drain valve. All fryers are equipped with side hanging twin baskets. Fryers are equipped with an adjustable gas thermostat from 200° to 375°, safety valve, pilot control, and high limit safety thermostat. Nickel plated 4" legs with a 1-3/8" adjustment are standard. Available in natural or propane gas.

### Warranty:

Star-Max gas fryers are covered by Star's one year parts and labor warranty.



Star-Max<sup>®</sup> Gas Underfired Counter Fryers



Star Manufacturing International, Inc.

Star-Max® Gas Underfired Fryers

## STAR-MAX® GAS FRYERS

### Models 615FD & 630FD

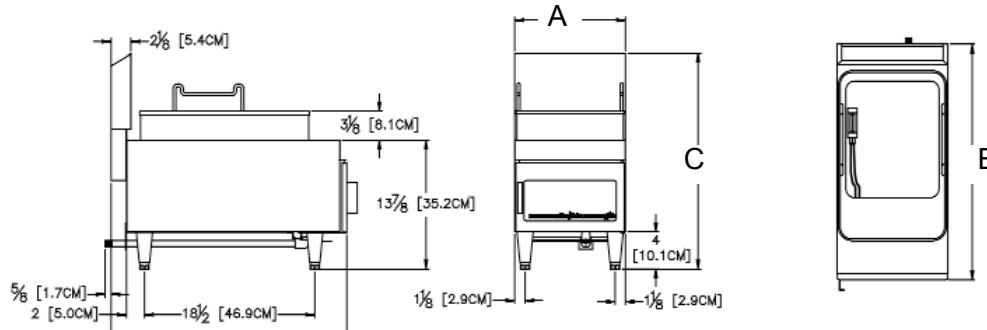

#### Performance Data

Model No.	Pre-Heat to 350°F (177°C)	Fat Capacity lbs. (kg)	Pounds of French Fries Per Hour lbs. (kg)	BTU's Per Hour To Maintain 350°F (177°C)
615FD	14 Minutes	15 (6.8)	28 (12.7)	4900
630FD	12 Minutes	30 (13.6)	65 (29.5)	5500

#### Dimensions & Weight

Model No.	Overall Dimensions			Approximate Weight	
	(A) Width Inches (cm)	(B) Depth Inches (cm)	(C) Height Inches (cm)	Installed lbs. (kg)	Shipping lbs. (kg)
615FD	12 (30.5)	25-1/8 (64)	23-3/8 (59)	64 (29.1)	75 (34.1)
630FD	24 (61)	25-1/8 (64)	23-3/8 (59)	110 (50)	118 (54)

Model No.	Fat Container			Foam Compartment		
	Width Inches (cm)	Depth Inches (cm)	Height Inches (cm)	Width Inches (cm)	Depth Inches (cm)	Height Inches (cm)
615FD	10-1/5 (26.7)	12-1/2 (31.8)	4-3/4 (12.1)	11-1/2 (29.2)	18 (45.7)	2-3/4 (7)
630FD	20-7/8 (53)	12-1/2 (32)	4-3/4 (12)	21-7/8 (56)	18 (46)	2-3/4 (7)

#### Gas Data

Model No.	BTU Rating		Type Connection
	Natural	Propane	
615FD	30,000/HR	30,000/HR	3/8" N.P.T Female (1 cm)
630FD	70,000/HR	65,000/HR	1/2" N.P.T. Female

#### Typical Specifications

Fryers have nickel plated steel kettle with a 1/4 turn drain valve. Kettle has copper fins attached to the bottom for maximum heat transfer and efficiency. Fryers are equipped with one-piece in shot burners, gas thermostat, hi-limit safety thermostat, twin baskets and a universal valve that is a combination safety valve, pilot control and main burner valve, 4" high die cast legs with a 1-3/8" adjustment are standard. Fryers available for use on natural gas or propane. Units are AGA certified and listed by the National Sanitation Foundation and certified by CGA. Printed in the U.S.A.

Due to periodic changes in designs, methods, procedures, policies and regulations, the specifications contained in this sheet are subject to change without notice. While Star Manufacturing exercises good faith efforts to provide information that is accurate, we are not responsible for errors or omissions in information provided or conclusions reached as a result of using the specifications. By using the information provided, the user assumes all risks in connection with such use.

Star Manufacturing International Inc. - 10 Sunnen Drive - P.O. Box 430129 - St. Louis, MO 63143-3800  
Phone: (800) 264-7827 - FAX: (800) 264-6666 - www.star-mfg.com