

# BOTTOM MOUNT UPRIGHT REACH-IN DUAL TEMP

## Bottom Mount Condensing Unit

Project Name: \_\_\_\_\_

Project Location: \_\_\_\_\_

Model #: \_\_\_\_\_ Quantity: \_\_\_\_\_

Available Warehouse: \_\_\_\_\_

**EB Series**

**Model: EBRF3**



### Refrigeration System

- Bottom mounted, self-contained and retractable condensing unit uses environmentally friendly R404A\* refrigerant with zero (0) Ozone Depletion Potential (ODP) and EPA compliant R290 refrigerant with zero (0) Ozone Depletion Potential (ODP) and three (3) Global Warming Potential (GWP). R290 condensing units are replaceable and require no on-site brazing. \*Ask about alternative refrigerant.
- PSC evaporator fan motors for R404A models. Electronically commutated (ECM) fan motors for R290 models.
- Airflow guard ensures optimal circulation of cold air. R290 models include full-length air duct system.
- Time-initiated and temperature-terminated auto defrost heater for R404A and R290 freezers. Air defrost for R290 refrigerators.
- Large capacity, corrosion-resistant condenser and evaporator coils.
- Self-maintaining, energy-efficient condensate drain pan requires no external drains or electric heaters.
- High performance condenser fan motors ensure efficient compressor ventilation. R290 models use auto-reverse condenser fan motors which also support condenser coil cleaning. Refer to owner's manual for full maintenance instructions.
- Pressure relief devices allow smooth access to cabinet interior when re-opening doors.
- Pre-wired and ready to plug, 115V/60Hz/1Ph, NEMA 5-15P.

### Cabinet Construction

- Heavy duty stainless steel interior / exterior with rounded corners for a hazard-free workspace.
- Galvanized steel top, bottom and rear.
- 2.5" thick high density polyurethane insulation.
- Deeper cabinet interior for more storage options.
- Six 5" swivel casters with locks on front set and three front leg stabilizers.

### Lighting

- Energy efficient silicone coated and shatter-proof LED lighting provides bright, high color illumination with low heat output.

### Doors

- Heavy duty stainless steel interior / exterior.
- 2.5" thick high density polyurethane insulation.
- Frame heaters prevent exterior moisture build up.
- Self-closing with adjustable torsion system for a positive seal.
- Snap-in magnetic door gasket make cleaning and replacement an easy process.
- High strength, recessed door handles.
- Pre-installed door locks keep your items safe from theft.
- Field reversible.

### Shelving

- Epoxy coated, steel wire shelves (see table for quantity).
- Height adjustable stainless steel clips.

### Temperature Control

- Multi-function digital controller with easy to read LED display.
- Factory preset temperature, 35°F for refrigerators and -4°F for freezers. Temperature setting range from 33°F to 54°F for refrigerators and -10°F to 54°F for freezers.
- R290 models include audible overheat protection alarm for compressor and condenser coil.

### Options

- Additional shelving.
- 3" swivel casters with locks.
- 3.5" – 6" height-adjustable and interchangeable legs.
- Left hinged door.

**Operating temperature range is 33°F ~ 54°F for Refrigerator and -10°F ~ 54°F for freezer**



**5 YEAR Compressor  
3 YEAR Parts & Labor**



Please visit our website for updated Energy Efficiency information

Ref/ Frz/Dual	Doors	Capacity Cu. Ft.	Shelves	Refrigerant	HP	Power V-Hz-Ph	Amps	Crated Weight	Exterior Dimensions		
									L	D	H*
DUAL	3	46(R) 22(F)	9	R-404A/R-290	1/3+ (R) 1/2 (F)	115-60-1	14.06	698 lbs (317kg)	74.75" (1899mm)	33.125" (841mm)	77" (1956mm)

(†)Based on evaporating temperature of 23°F (-5°C) & condensing temperature of 131°F (55°C). (P) Product capacity is calculated based on standard industry figures. (x) Reference plan view for clarification on caster/unit height. If dimensions and capacity are critical, please contact Everest Refrigeration. Blizzard R290 replacement is at the sole discretion of Everest Refrigeration. Specifications subject to change without notice.

# BOTTOM MOUNT UPRIGHT REACH-IN DUAL TEMP

## Bottom Mount Condensing Unit

**EB Series**

**Model: EBRF3**

**DIMENSIONAL DATA**

<b>External Dimensions</b>	L	74.75" (1899mm)
	D	33.125" (841mm)
	H*	77" (1956mm)
<b>Crated Weight</b>		698 lbs. (317kg)
<b>Doors/Drawers/Lids</b>		3
<b>Max Weight Support (LBS)</b>		-

**STORAGE DATA**

<b>Net Capacity Cu. Ft. <sup>†</sup></b>	46(R) 22(F)
<b>Shelves</b>	9
<b>Barrels</b>	-
<b>20 oz. Bottles</b>	-
<b>12 oz. Bottles</b>	-
<b>12 oz. Cans</b>	-
<b>8" Mugs</b>	-
<b># of Pans (Top)</b>	-
<b># of Pans (Drawer)</b>	-
<b>Dividers</b>	-
<b>Trays</b>	-

**ELECTRICAL DATA**

<b>Voltage</b>	115-60-1
<b>Full Load Amperage</b>	14.06
<b>Feed Wires with Ground</b>	3
<b>Cord Length</b>	9ft
<b>NEMA Plug Type</b>	Ⓜ NEMA 5-15P

**REFRIGERATION DATA**

<b>Compressor Mounting</b>	Bottom
<b>Refrigerant</b>	R-404A/R-290
<b>Compressor HP</b>	1/3+ (R) 1/2 (F)
<b>BTU/HR <sup>†</sup></b>	2612(R) 3435(F)

**KEY**

<b>R</b>	Refrigerator	<b>D</b>	Door
<b>REF</b>	Refrigerator	<b>L</b>	Lid
<b>F</b>	Freezer	<b>H</b>	Half Door
<b>FRZ</b>	Freezer	<b>FD</b>	Full Door
<b>DUAL</b>	REF/FRZ Combo	<b>SD</b>	Solid Door
<b>DR</b>	Drawer	<b>GD</b>	Glass Door

	<b>Elevation</b>	<b>Right</b>	<b>Plan</b>	<b>3D</b>	<b>Back</b>

**PLAN VIEW**

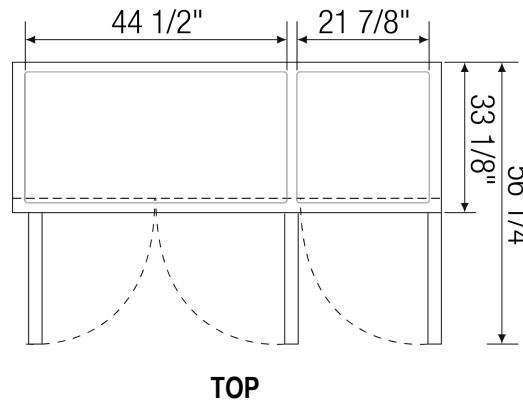
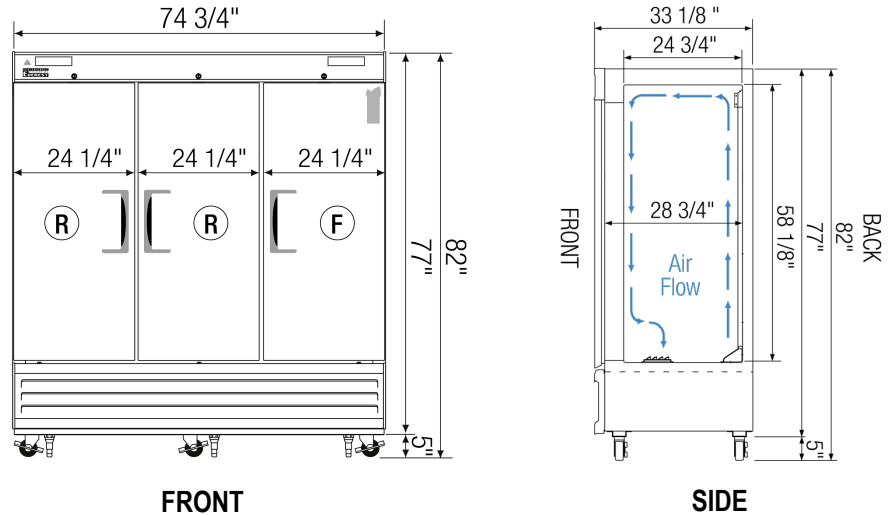

**ACCESSORIES & OPTIONS**

Part Number	Description
<b>Additional Shelving</b>	Contact Everest Refrigeration for more information.
<b>AJL03-00</b>	Interchangeable Leg for Caster
<b>CASA3-02</b>	3" Overall Height Caster Assembly - (3) Front (3) Rear
<b>Left Hinged Door</b>	Contact Everest Refrigeration for more information.

(†)Based on evaporating temperature of 23°F (-5°C) & condensing temperature of 131°F (55°C). (‡) Product capacity is calculated based on standard industry figures. (✱) Reference plan view for clarification on caster/unit height. If dimensions and capacity are critical, please contact Everest Refrigeration. Blizzard R290 replacement is at the sole discretion of Everest Refrigeration. Specifications subject to change without notice.