



Our main ingredient is value

G-PEELER

MADE IN THE USA

G PEELER

# 20 POUND VEGETABLE PEELER

## PORTABLE 20 LB. CAPACITY PEELER

WITH DURABLE PEELING DISC

A Univex Portable Vegetable Peeler means economy and efficiency in preparing potatoes, carrots and other root vegetables.

With your UNIVEX Peeler you maintain fresh, nutritious flavor - lost in frozen and pre-cut vegetables - and make a profit by peeling your own vegetables.

Old-fashioned and peeling took half an hour to peel twenty pounds of potatoes - and up to 35% was waste! UNIVEX can do the same job in 2 to 3 minutes - and cut the waste to less than 10%.

Some customers use the UNIVEX PEELER to clean shellfish and scale small fish.



- Truly portable. Plugs in anywhere - like a toaster.
- Stainless steel construction insures long life, makes cleaning easy.
- Corrosion resistant cover.
- Precision timer - automatically shuts off as desired, prevents over-peeling.
- Extended discharge chute, minimizes splashing.
- Quick easy Lock Door.
- Flexible water inlet, connects to sink tap.
- New, silent double "V" belt drive - 1/3 hp AC Motor.
- No plumbing problem - operates on drainboard, Univex Mobile Stand, counter or table.



### WARRANTY

The Univex G-Peeler carries a one-year, on-site parts and labor warranty against any flaws in materials and workmanship. This period begins with the date of purchase and, provided the unit is used properly in accordance with our instructions, is in full effect for one year from that date. Any work to be performed under this warranty must be performed between the hours of 8:00 a.m. and 5:00 p.m. local time, Monday through Friday. Univex will not pay overtime charges for work performed other than during normal business hours. Damages incurred in transit or from installation error, accident, alteration or misuse are not covered. Transit damages should be reported to the carrier immediately. Univex shall not be liable for any consequential, compensatory, incidental, or special damages. Contact Univex Service Department for any warranty claims.



UNIVEX CORPORATION ■ 3 Old Rockingham Road ■ Salem, NH 03079-2140  
Tel 603-893-6191 ■ Fax 603-893-1249 ■ E-mail [univex@univexcorp.com](mailto:univex@univexcorp.com)  
TOLL-FREE ORDERING FAX 1-800-356-5614  
[www.univexcorp.com](http://www.univexcorp.com)

April 2005  
Printed in USA

# 20 POUND VEGETABLE PEELER

MODEL G

G PEELER

20 POUND CAPACITY PEELER

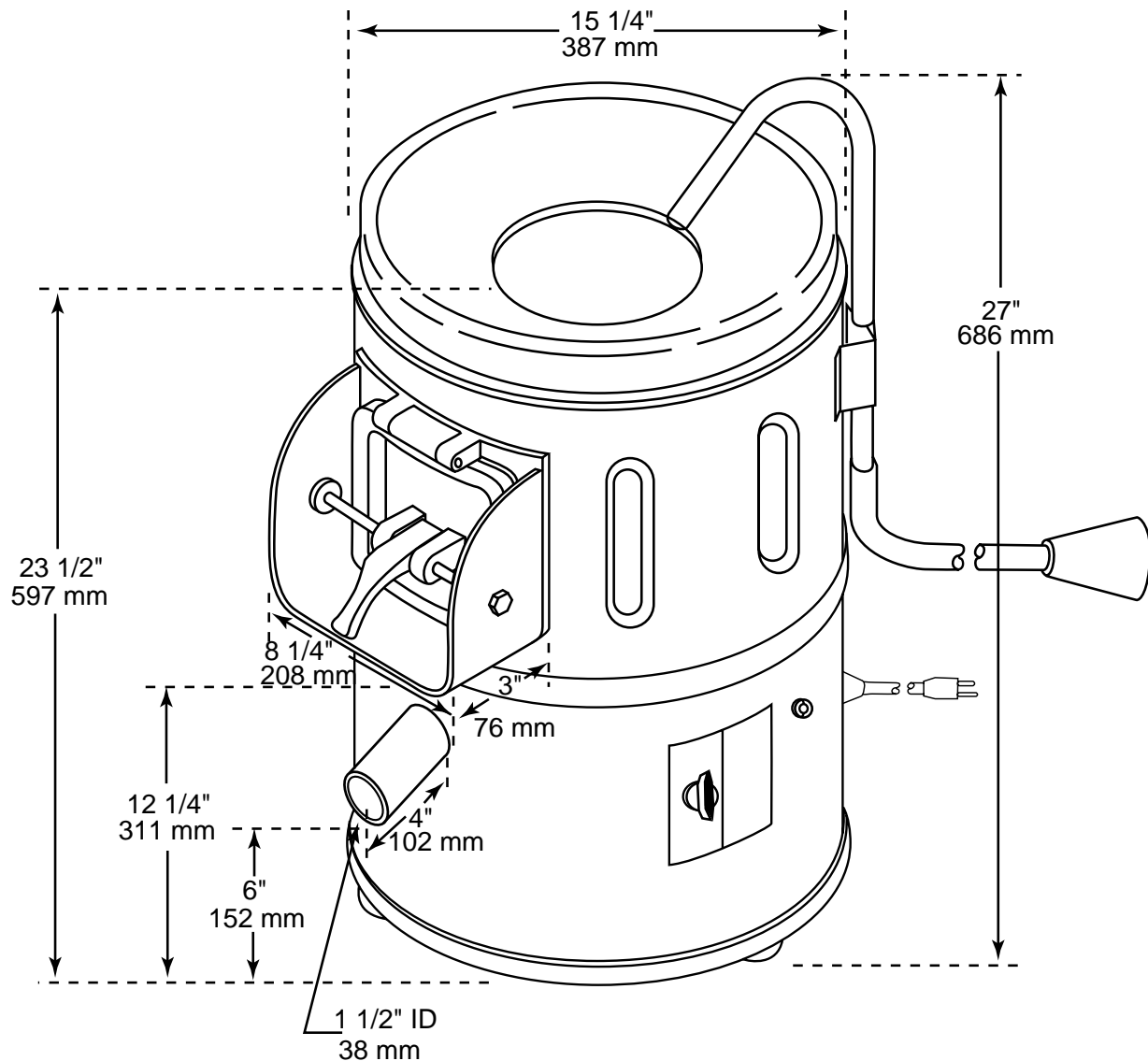

G-PEELER

## SPECIFICATIONS

<b>Electrical</b>	115V / 208-230V / 6.2 Amp. / 3.0-3.1 Amp. / 1ph. *Consult factory for special voltages.
<b>Motor /Drive</b>	1/3 HP, 1725 RPM
<b>Controls</b>	Timer Switch, 5 minute maximum
<b>Housing</b>	Stainless Steel
<b>Body Dimensions</b>	23 1/2" (570mm) high x 15" (381mm) diameter
<b>Net Weight</b>	72 lbs. (33Kg)
<b>Shipping Weight</b>	86 lbs. (39 Kg)
<b>Box Dimensions</b>	28" (711mm) high, 22" (559mm) wide, 19" (483mm) long



UNIVEX CORPORATION ■ 3 Old Rockingham Road ■ Salem, NH 03079-2140  
Tel 603-893-6191 ■ Fax 603-893-1249 ■ E-mail univex@univexcorp.com  
TOLL-FREE ORDERING FAX 1-800-356-5614  
[www.univexcorp.com](http://www.univexcorp.com)

April 2005  
Printed in USA