



Majestic Series Milk Dispensers

MODELS SKMAJ1 - SKMAJ2 - SKMAJ3



MODEL	DESCRIPTION	LENGTH	DEPTH	HEIGHT	COMPRESSOR	AMPS	WEIGHT
C4 SERIES: Includes 6 gallon crate(s) and platform(s)							
SKMAJ1/C4	Single valve, accommodates 3, 5 and 6 gallon	15 1/2"	17 1/8"	39 1/2"	1/10 hp	1.5	120 lbs
SKMAJ2/C4	Double valve, accommodates 3, 5 and 6 gallon	26 1/2"	17 1/8"	39 1/2"	1/10 hp	1.4	160 lbs
SKMAJ3/C4	Triple valve, accommodates 3, 5 and 6 gallon	37 1/2"	17 1/8"	39 1/2"	1/8 hp	1.9	200 lbs
C3 SERIES: With shipboard legs; includes 6 gallon crate(s) and platform(s)							
SKMAJ1/C3	Single valve, accommodates 3, 5 or 6 gallon	15 1/2"	17 1/8"	39 1/2"	1/10 hp	1.5	120 lbs
SKMAJ2/C3	Double valve, accommodates 3, 5 or 6 gallon	26 1/2"	17 1/8"	39 1/2"	1/10 hp	1.4	160 lbs
SKMAJ3/C3	Triple valve, accommodates 3, 5 or 6 gallon	37 1/2"	17 1/8"	39 1/2"	1/8 hp	1.9	200 lbs

- CABINET** Stainless steel exterior and interior.
- REFRIGERATION** CFC-free, 134a refrigerant, hermetically sealed, high efficiency, self contained refrigeration system. Adjustable temperature control and temperature indicator on front of door.
- DOOR** Heavy duty hinges. Easily removable door gasket for ease in cleaning.
- DISPENSER VALVE** Spring loaded lift type valve for dripless operation and optimum sanitation.
- ELECTRICAL** Standard 115 volt, 60 Hz, single phase. Also available in 230 volt, 50Hz, single phase.
- LISTINGS** ETL Safety (U.S. and Canada), ETL Sanitation.
- WARRANTY** One year parts and labor warranty on cabinet and refrigeration system. Five year warranty on compressor.



1600 Xenium Lane North
 Minneapolis, MN 55441-3787
 Phone (763) 923-2441
 Fax (763) 553-1209
 www.silverking.com



Specifications subject to change without notice.

6/2015
 © Silver King 2015
 Printed in U.S.A.



MAJESTIC SERIES MILK DISPENSERS

SKMAJ1

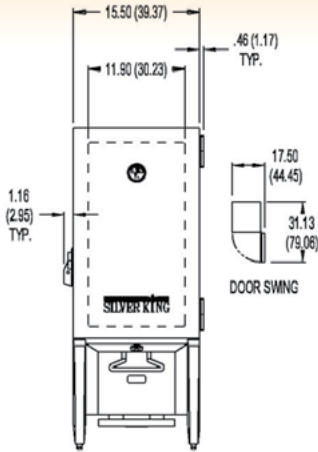

SKMAJ2

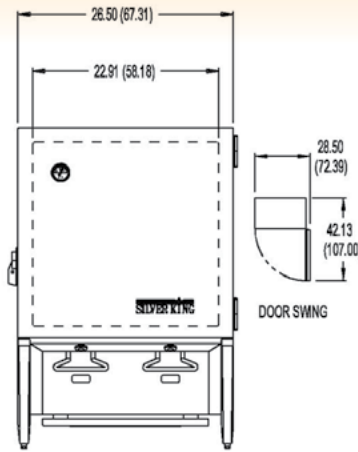

Application: Milk in bag
(3, 5 or 6 gallon)



Application: Bag-n-box milk

SKMAJ3

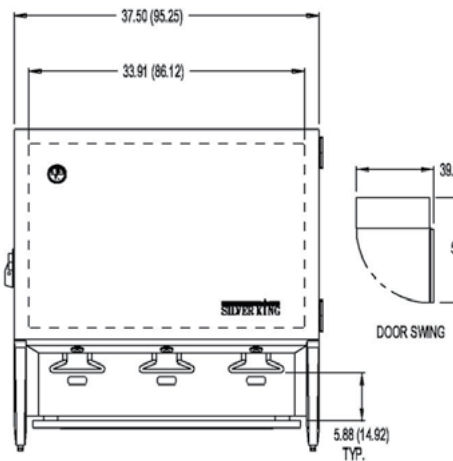

COMMON SIDE VIEW

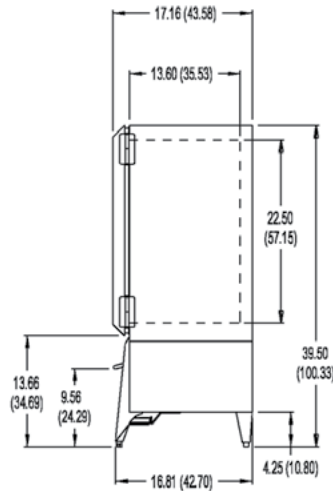

Application: Bag-n-box milk



Application: 5 gallon dispenser can
(sold as accessory)

ACCESSORIES



Milk crate for 3, 5 or 6 gallon bags
Item # 35904



Platform for bag-n-box milk
Item # 63959



3 gallon dispenser can
Item # 62642



5 gallon dispenser can
Item # 60224



Tubes 10 1/4"
Item # 20323



1600 Xenium Lane North
Minneapolis, MN 55441-3787
Phone (763) 923-2441
Fax (763) 553-1209
www.silverking.com



Specifications subject to change without notice.

6/2015
© Silver King 2015
Printed in U.S.A.