



COLD FOOD HOLDERS {BAR COMBO'S} STAINLESS STEEL PUMPS

Models **SB-2, SB-2 DI**
SB-3, SB-3 DI
SB-4, SB-4 DI

Date:

Project:

Quantity:

Item Number:



SB-2 DI 79950

Bid Description

Insulated serving bars are constructed of a stainless steel exterior with a one-piece seamless plastic interior. Serving Bars can be cooled with ice, (1) Eutectic Ice Pack (94141) per jar or our deep fountain HOLDCOLD™ jars (not included).

Pump combination models come complete with multiples of: deep polypropylene fountain jars (82557) and CP-F (83330) pumps. Choose from countertop or drop-in models.

Stainless steel CP-F condiment pumps feature a rugged cast valve body and welded construction. Maximum stroke yields 1¼ ounce (37 mL) with gauging collars supplied to reduce yield in ⅛ ounce (3.7 mL) increments.



SB-3 DI 83860

Standard Features

Stainless steel exterior, seamless plastic interior, and insulation

Maximum stroke yields 1¼ oz (37 mL), now adjustable in ⅛ oz (3.7 mL) increments — allows for Portion Optimization™

Stainless steel hinged lid attaches to lid in a snap

Colored, engraved knobs to identify contents are available upon request

Insulated Bar Combo's with Pumps

<u>Includes</u>	<u>Countertop</u>	<u>Drop-In</u>
(2) jars	SB-2 79890	SB-2 DI 79950
(3) jars	SB-3 83790	SB-3 DI 83860
(4) jars	SB-4 83700	SB-4 DI 83720



SB-4 83700

Insulated Bar - Base Only

To put together your own combination, choose a base unit from below and components from the Bar & Rail Accessory sheet.

<u>Accepts</u>	<u>Countertop</u>	<u>Drop-In</u>
(2) jars	SB-2 80160	SB-2 DI 80150
(3) jars	SB-3 83760	SB-3 DI 83830
(4) jars	SB-4 83600	SB-4 DI 83620

Warranty

Server Products equipment is backed by a two-year limited warranty against defects in materials and workmanship. For our complete warranty statement, please see our web site.



THIN THICK PARTICULATE
See category tab for details.

Specifications on reverse side



COLD FOOD HOLDERS {BAR COMBO'S} STAINLESS STEEL PUMPS

Models **SB-2, SB-2 DI**
SB-3, SB-3 DI
SB-4, SB-4 DI

Serving Bar—Counter-top

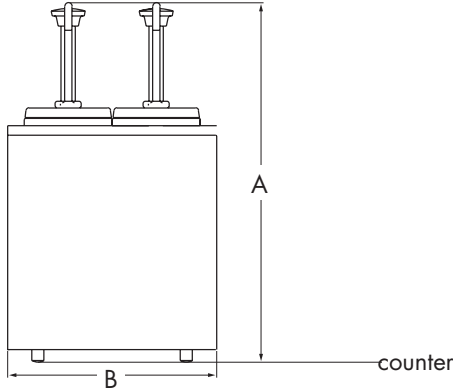

Serving Bar—Drop-In

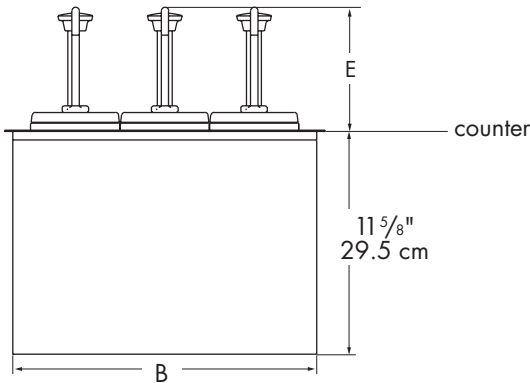

Serving Bar—Counter-top & Drop-in

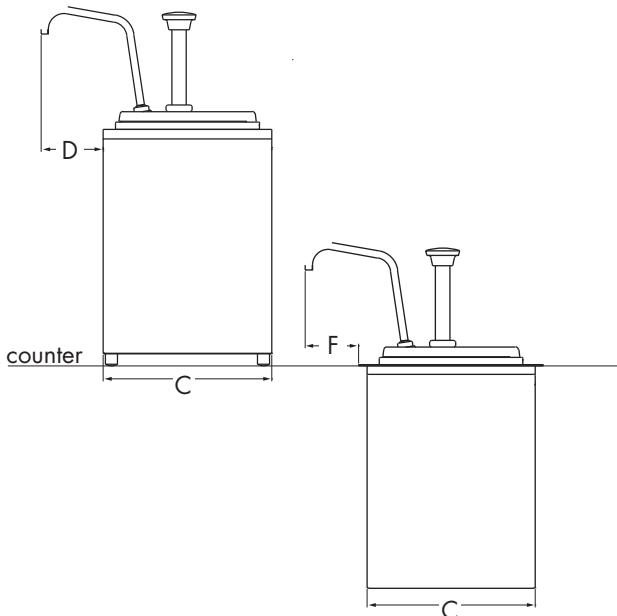

Specifications

Construction	Stainless steel exterior, seamless plastic interior, and insulation.		
Jar Capacity	Shallow	Deep	HOLDCOLD™
	2 qt 1.9 L	3 1/2 qt 3.3 L	2 1/4 qt 2.1 L
Counter-Top	(2) Jar	(3) Jar	(4) Jar
A-Height	in 19 3/8 cm 49.2	in 19 3/8 cm 49.2	in 19 3/8 cm 49.2
B-Width	in 10 7/8 cm 27.6	in 15 1/2 cm 39.4	in 20 1/8 cm 51.1
C-Depth	in 8 13/16 cm 22.4	in 8 13/16 cm 22.4	in 8 13/16 cm 22.4
D-Spout {Depth}	in 3 1/4 cm 8.3	in 3 1/4 cm 8.3	in 3 1/4 cm 8.3
Drop-In	(2) Jar	(3) Jar	(4) Jar
E-Height	in 6 7/16 cm 16.4	in 6 7/16 cm 16.4	in 6 7/16 cm 16.4
B-Width	in 10 7/8 cm 27.6	in 15 1/2 cm 39.4	in 20 1/8 cm 51.1
C-Depth	in 8 13/16 cm 22.4	in 8 13/16 cm 22.4	in 8 13/16 cm 22.4
F-Spout {Depth}	in 2 13/16 cm 7.1	in 2 13/16 cm 7.1	in 2 13/16 cm 7.1
Cutout Size			
SB-2 DI	11 x 8 7/8" (27.9 x 22.5 cm)		
SB-3 DI	15 5/8 x 8 7/8" (39.7 x 22.5 cm)		
SB-4 DI	20 1/4 x 8 7/8" (51.4 x 22.5 cm)		

FOB Richfield, Wisconsin 53076

CAD Library

Individual CAD images can be downloaded from product pages on our web site. We are also a member of The KCL CADalog with more than 100 other manufacturers. Our complete collection of CAD files can be purchased through Kochman Consultants, Ltd. at klcad.com.

