



COMMERCIAL RESIN FURNITURE

Your best value for Food Service & Hospitality!

E
X
T
E
R
I
O
R

New!

Havana Classic Stacking Barstool with Arms

Tested and certified in compliance with the
ASTM F 1561-03 Class B performance standard
for commercial use.

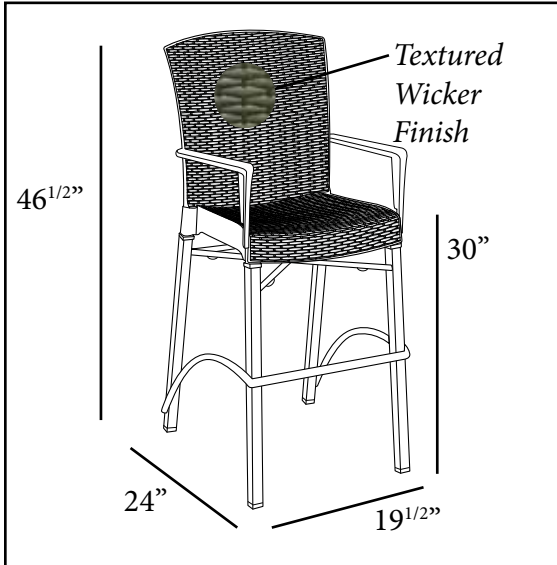

Features & Benefits **Warranty: 3 Yrs.**

- Barstool with armrests for extra comfort!
- The All-Weather Wicker performance, without the maintenance!
- A product of Grosfillex MPC Technology®
- Stacks for easy storage.
- Rated to 300 lbs. for safe use in commercial areas.
- Texture will not harbor dirt, sand, food, bacteria nor fungi.
- Easy to clean with soap and mild detergent and water.
- 1 1/4" square powder coated aluminum legs with hard wearing footpads for structural integrity.
- Color-fast - no resin strand to unravel.
- Made in the U.S.A. from U.S. and imported parts.

Product Specifications						
Product Description	Reference Number	Color	UPC Code	Weight Each (lbs.)	Master Pack	Master Pack Volume (cu. ft.)
New!Havana Classic Stacking Barstool with Arms	48260002	Charcoal	923048	29.60	1	18.72
	48260037	Espresso	923017	29.60	1	18.72
	48260004	White	923031	29.60	1	18.72
	48260008	Tobacco	923024	29.60	1	18.72

[Click here to buy now!](#)



1-866-285-1252