

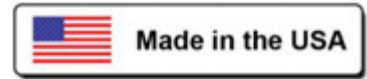

JOB:
ITEM:
QTY:



1/2 SIZE BUN PAN RACK

APPLICATION:

These racks are designed to transport and hold 18" x 26", 13" x 18", and 14" x 18" pans. The half size design creates a working top height. Options for the top are stainless steel, aluminum, or poly-top. You can also leave it open for a roll in application.

MATERIAL:

Framework is constructed of 1" x 1" x .070" wall tubing. Angle runners are 1 1/4" x 1 5/8" x .100" wall. Uprights have a reinforcing channel to reinforce the tubing wall to help prevent breakage from the stem caster.

CASTERS:

These racks come equipped with four 5" stem type swivel casters for easy maneuverability.

GUARANTEE:

These racks carry a **Lifetime Guarantee** against rust and corrosion and also carry a **Five-Year Guarantee** against material defects and workmanship.



Model #1311



Phone: 800-255-0104
Fax: 877-877-7687
www.newageindustrial.com
sales@newageindustrial.com

New Age Industrial reserves the right to modify or make changes at any time without notice to materials and specifications.

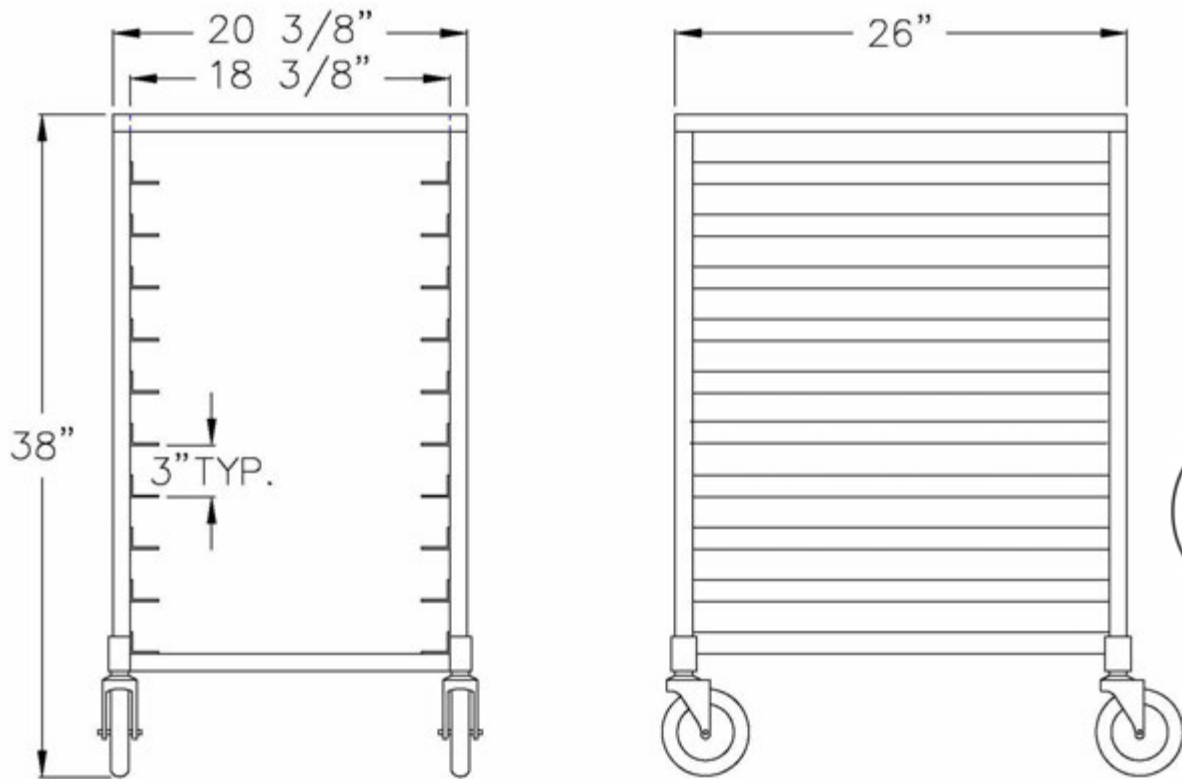

Model #1311

Model No.	Size-W	Size-H	Size-D	Runner Spacing	Pan Cap.	Top Type
UNDER-COUNTER SIZE						
1313	20 3/8"	32 1/4"	26"	3"	8	Stainless
1314	20 3/8"	32 1/4"	26"	3"	8	None
BAKERY 1/2 SIZE WITH POLY TOP						
95958	20 3/8"	33 1/2"	26"	4 1/2"	5	Poly
REGULAR 1/2 SIZE						
1311	20 3/8"	38"	26"	3"	10	Stainless
1312	20 3/8"	38"	26"	3"	10	None
92096	20 3/8"	39"	26"	3"	10	Poly
1321	20 3/8"	38"	26"	5"	6	Stainless
1322	20 3/8"	38"	26"	5"	6	None
REPLACEMENT TOP						
45106	20 3/8" X 26"			Stainless Steel		
45256	20 3/8" X 26"			Aluminum		



Phone: 800-255-0104
 Fax: 877-877-7687
www.newageindustrial.com
sales@newageindustrial.com

New Age Industrial reserves the right to modify or make changes at any time without notice to materials and specifications.