

# CENPRO

## ALUMINUM BUN PAN RACK MANUAL



**Central Restaurant Products®**

7750 Georgetown Road • Indianapolis, IN 46268

800.222.5107 • [www.centralrestaurant.com](http://www.centralrestaurant.com)

# ALUMINUM BUN PAN RACK MANUAL

Thank you for choosing CenPro. We design every CenPro solution with the end-user in mind, providing the best value for all storage and transport needs. CenPro bun pan racks are NSF-approved, constructed of durable aluminum and easy to assemble. Visit [www.central-restaurant.com](http://www.central-restaurant.com) for the full line of CenPro solutions.

## TABLE OF **Contents**

**03 RECEIVING** INSTRUCTIONS

---

**04 ASSEMBLY** INSTRUCTIONS

---

**08 CLEANING** INSTRUCTIONS

---

**09 WARRANTY** INFORMATION

---

# ALUMINUM BUN PAN RACK MANUAL

## Receiving & Inspecting EQUIPMENT

Unload carefully to avoid damage.

1. Visually inspect the package exterior, noting any damage and immediately reporting it to the delivery carrier.
2. If you note any damage to the exterior, open and inspect the contents of the package with the carrier.
3. If there is no damage to the exterior, yet you notice damage to the contents upon opening, immediately notify the carrier verbally and in writing.
4. In the event you notice damage after opening, request an inspection to be conducted by the shipping company. This should be conducted within 10 days of receipt.
5. The freight carrier can supply necessary damage forms upon request.
6. Retain all crating material until an inspection has been conducted or waived

# ALUMINUM BUN PAN RACK MANUAL

## Assembly INSTRUCTIONS

### Bun Pan Racks

1. Open packaging and locate all of the following contents:

Aluminum Bakery Rack		
Part	QTY	Description
1	2	Side Frame
2	2	1" Cross Bar
3	4	3/4" Cross Bar
4	8	Collar
5	4	3/8-16x13/4" Hex Flange Bolt
6	8	1/4-20x1" Hex Bolt
7	4	Swivel Caster

# ALUMINUM BUN PAN RACK MANUAL

## Assembly INSTRUCTIONS

### Bun Pan Racks

2. Attach two casters (7) into the base of the side frame (1). Then, insert the hex flange bolt (5) through the opening at the top of the caster stem, threading into the 1" cross bar (2). Repeat process with the remaining swivel casters (7) and side frame (1). Do not tighten bolts until Step 4.

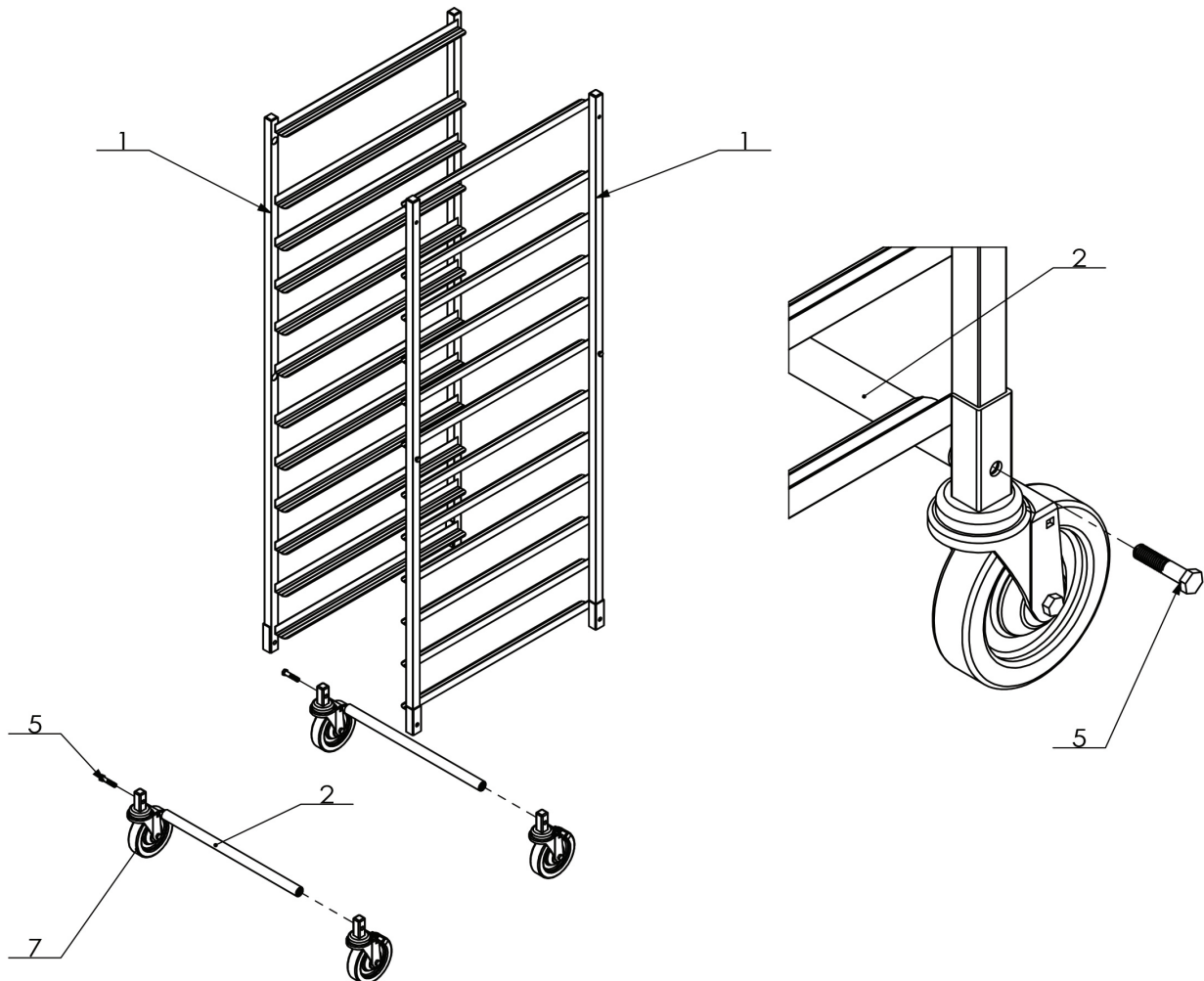

# ALUMINUM BUN PAN RACK MANUAL

## Assembly INSTRUCTIONS

### Bun Pan Racks

3. Attach the 3/4" cross bars (3). Add a collar (4) over the outside of the frame and hand thread the hex bolts (6).

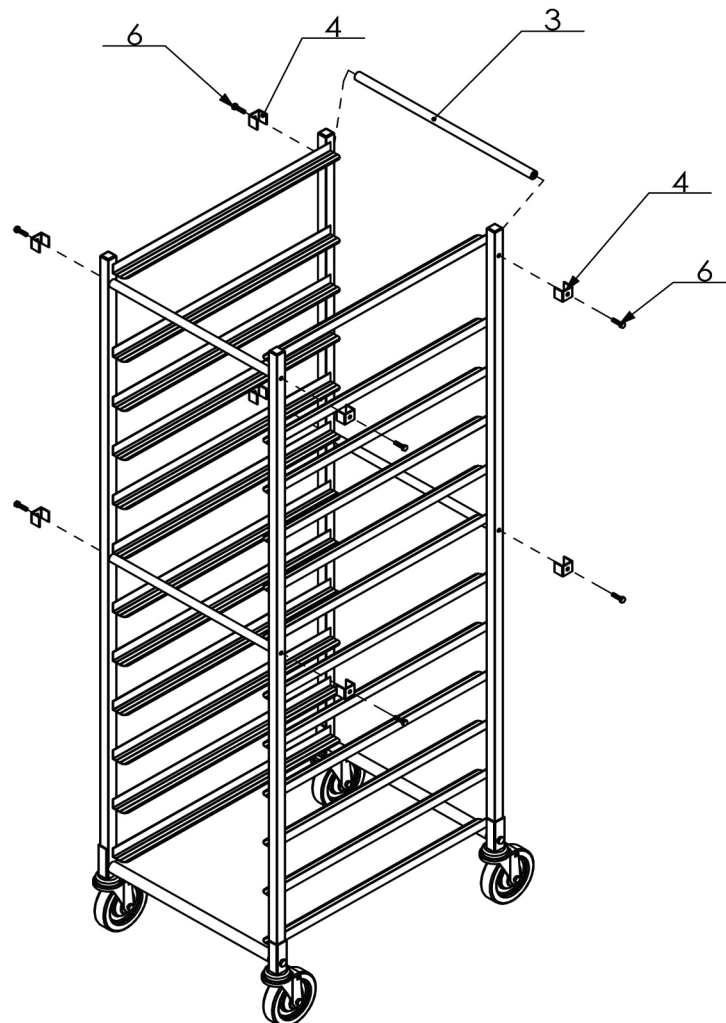

# ALUMINUM BUN PAN RACK MANUAL

## Assembly INSTRUCTIONS

### Bun Pan Racks

4. Tighten all bolts withg correct-sized wrench or socket; do not overtighten bolts. Ad

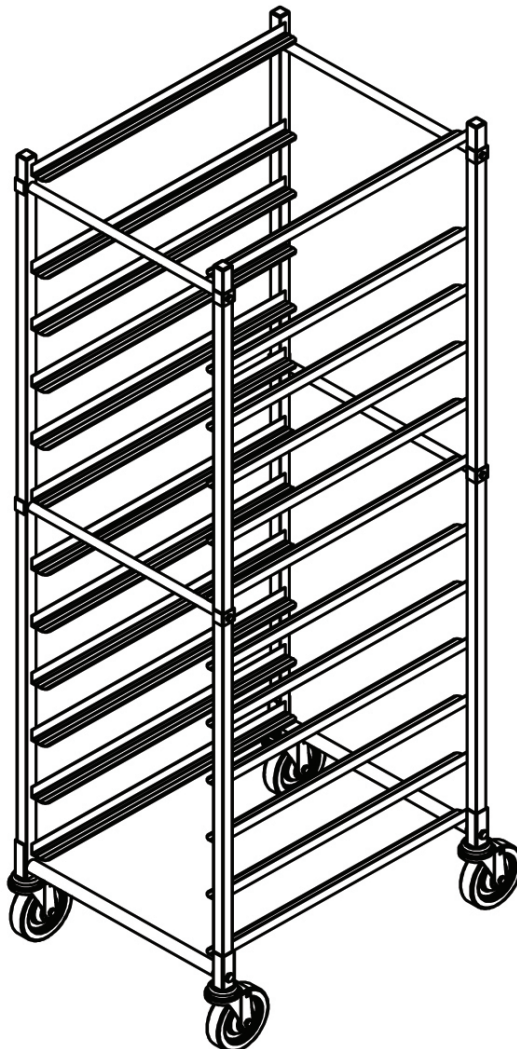

# ALUMINUM BUN PAN RACK MANUAL

## Cleaning INSTRUCTIONS

1. Use a soft cloth or nylon brush to clear the cart of debris before cleaning.
  - a. Do not use stiff cleaning tools or scrubbers that can scratch the stainless steel and will result in a voided warranty.
2. Wash with a mild soap or detergent.
  - a. Do not use harsh or abrasive chemicals on your cart. This will cause damage to the table and void the warranty
3. Follow by rinsing with clean water
4. Wipe dry with a soft cloth or disposable wipe.



# ALUMINUM BUN PAN RACK MANUAL

## Warranty INFORMATION

### 90 Day Limited Warranty

A 90-day limited warranty, beginning from the date of delivery, is valid on new equipment and to the original purchaser. This warranty ensures the product will be free of material or workmanship defects. At its own discretion, CenPro will provide replacement parts, replace the unit, or issue a refund for the original purchase price. This warranty is non-transferrable.

CenPro's 90-day limited warranty does not cover:

- Mobile applications where damage may result due from improper securement to the floor.
- Products that have been modified or used in any way other than their intended use.
- Any products sold outside the continental United States.
- Any products where the original sale cannot be determined. Users must be able to provide proof of purchase, using an order number, invoice, or receipt.
- Labor or service not authorized by CenPro.
- Compensation for freight damage must be arranged with the carrier and requested at the time of delivery.
- Exposure to corrosive cleaners or other chemicals not intended for use on aluminum or stainless steel will void the warranty.
- Use outdoors will void the warranty.
- CenPro is not liable for any parties that experience loss of product, business, or other expenses, or consequential damage.

For warranty information, contact the location where the original purchase was made.

If purchased on [www.centralrestaurant.com](http://www.centralrestaurant.com), **call 800.215.9293** or **email [sales@centralrestaurant.com](mailto:sales@centralrestaurant.com)**.