



POPCORN MACHINE

CSLPOP1-BK

8 oz. Stainless Steel Kettle
 Lighted cabinet
 ETL certified

POPCORN CART

CSLPOP1CART-BK

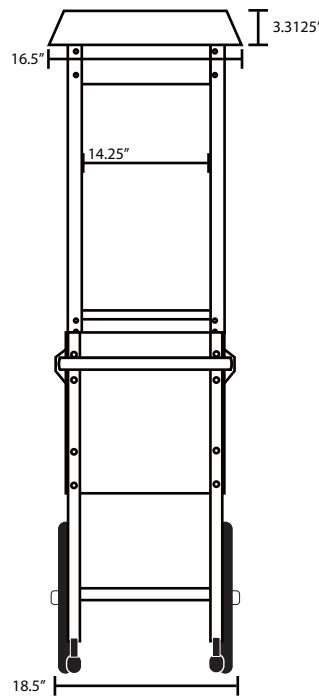
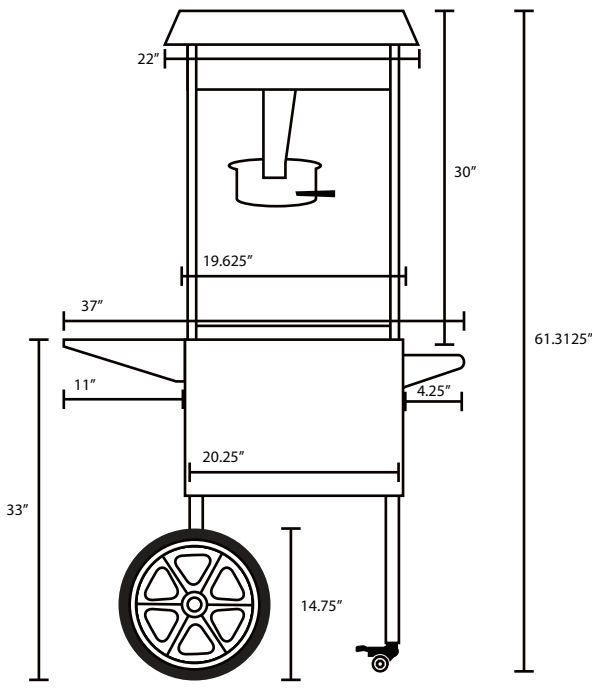

SPECIFICATIONS

| ITEM # | DESCRIPTION | PRODUCT WEIGHT (LBS.) | PRODUCT DIMENSIONS | MASTER CARTON WEIGHT (LBS.) |
|----------------|---|-----------------------|---------------------|-----------------------------|
| CSLPOP1-BK | Popcorn Machine, 8 oz, Stainless Kettle | 53 | 14.25 x 19.625 x 30 | 57 lbs |
| CSLPOP1CART-BK | Cart for CSLPOP1-BK | 44 | 18.5 x 37 x 33 | 48.5 lbs |

Due to periodic changes in designs, methods, procedures, policies and regulations, the specifications contained in this sheet are subject to change without notice. While we exercise good faith efforts to provide information that is accurate, we are not responsible for errors or omissions in information provided or conclusions reached as a result of using the specifications. By using the information provided, the user assumes all risks in connection with such use.

2/2016